PROJECT

_____ COUNTY COMMISSIONERS

BID DOCUMENTS PREPARED BY:

HOCKING ATHENS PERRY COMMUNITY ACTION AGENCY

3 Cardaras Dr.

P.O. BOX 220

Glouster, Ohio 45732

740.767.4500

1.800.686.1093

TABLE OF CONTENTS

SECTION A: NOTICE TO CONTRACTORS

SECTION B: INSTRUCTIONS TO BIDDERS

1. Receipt and Opening of Bids
2. Preparation of Bid
3. Telegraphic Modifications
4. Method of Bidding
5. Qualification of Bidder
6. Bid Security
7. Liquidated Damages for Failure to Enter into Contract
8. Conditions of Work
9. Obligation of Bidder
10. Examination of Site
11. Soil Conditions
12. Working Facilities
13. Addenda and Interpretations
14. Water Supply
15. Signature of Bidders
16. Notice of Special Conditions
17. Additional Obligations Upon Contract Award
18. Foreign Corporations and Contractors
19. Attachment A, "Qualitative and Responsible" Contractor Criteria

SECTION C: GENERAL CONTRACT CONDITIONS

- | | |
|-----------|-------------------------------|
| Article 1 | General Contract Documents |
| Article 2 | Performance and Payment Bonds |
| Article 3 | Wage Rates |
| Article 4 | Affirmative Action |
| Article 5 | Insurance |
| Article 6 | Safety |
| Article 7 | Permits |
| Article 8 | Supervision |

- | | |
|------------|-----------------------------------|
| Article 9 | Claims against the Contractor |
| Article 10 | Subcontracting |
| Article 11 | Change of Work |
| Article 12 | Time |
| Article 13 | Completion of Work |
| Article 14 | Termination |
| Article 15 | Payment |
| | ▪ Supplemental General Conditions |

SECTION D: WORK SPECIFICATIONS

- Project Specifications
- Project Location Map

SECTION E: DAVIS-BACON WAGE DETERMINATIONS

SECTION F: BID FORMS

- Bid for Unit Price Contracts
Signature Page
- Bid Guaranty and Contract Bond
Signature Page
- Affidavit of Contractor/Supplier of Non-Delinquency of Personal Property Taxes
- Non-Collusion Affidavit
- Certification Regarding Debarment, Suspension, and Other Responsibility Matters Primary Covered Transactions
- Affidavit in Compliance with Section 3517.13 of ORC
- Additional Certifications
- Bonding and Insurance Requirements
- Experience Statement
- Sales and Use Tax
- Ohio DMA Form
- W-9 Form
- Ohio New Hire Form

NOTICE TO CONTRACTORS

SECTION A

NOTICE TO CONTRACTORS

Sealed proposals for the _____ project will be received at the office of the _____ until _____. Plans, specifications and bid forms may be secured by contacting _____ at the office of Hocking Athens Perry Community Action, 3 Cardaras Dr., Glouster, OH 45732, (740)-767-4500, for a non-refundable fee of \$20.00. Plans, specifications, and bid forms may also be downloaded from www.hapcap.org at no charge.

Each bid must be accompanied by either a bid bond, in an amount of 100% of the bid amount with a surety satisfactory to the aforesaid _____, or by certified check, cashier's check, or irrevocable letter of credit from a solvent bank in the amount of not less than 10% of the bid amount in favor of the aforesaid _____. Bid Bonds shall be accompanied by Proof of Authority of the official or agent signing the bond.

Bids shall be sealed and marked as _____ and mailed or hand-delivered to:

Attention of bidders is called to all of the requirements contained in this bid packet, particularly to the Federal Davis-Bacon Wages, various insurance requirements, various equal opportunity provisions, and the requirement for a payment bond and performance bond for 100% of the contract price.

No bidder may withdraw their bid within ninety (90) days after the actual date of the bid opening thereof. The _____ reserve the right to waive any informality or to reject any or all bids.

INSTRUCTIONS TO BIDDERS

SECTION B

1. **RECEIPT AND OPENING OF BIDS:** The _____ (herein called the "Owner"), invite bids on the form attached hereto, all blanks of which must be appropriately completed. Bids will be received by the Owner at the office of the _____ until _____, at which time they will be publicly opened and read aloud. The envelopes containing the bids must be sealed and addressed to _____.
Envelopes must be designated for the _____.

The Owner may consider informal any bid not prepared and submitted in accordance with the provisions hereof and may waive any informalities or reject any and all bids. Any bid may be withdrawn prior to the above scheduled time for the opening of bids or authorized postponement thereof. Any bid received after the time and date specified shall not be considered. No bidder may withdraw a bid within ninety (90) days after the actual date of the opening thereof.

2. **PREPARATION OF BID:** Each bid must be submitted on the prescribed form and accompanied by the required form in Section F including a bid bond or certified check, the Non-Collusion Affidavit, Certification Regarding Debarment, Suspension, and Other Responsibility Matters Primary Covered Transactions, Experience Statement, Bonding and Insurance Requirements and the Statement on Delinquent Taxes. All blank spaces for bid prices must be filled in, in ink or typewritten, in both words and figures, and foregoing Certifications must be fully completed and executed when submitted.

The Bidder's total is his total bid based on his unit prices and lump sum prices and the estimated quantities shown on the plans. This figure is for information only at the time of opening bids. The owner will make the tabulation from the unit prices and lump sum prices bid. If there is an error in the total by the bidder, it shall be changed as only the unit prices and lump sum prices shall govern.

Each bid must be submitted in a sealed envelope, bearing on the outside, the name of the bidder, his/her address, and the name of the project for which the bid is submitted. If forwarded by mail, the sealed envelope containing the bid must be enclosed in another envelope addressed as specified in the bid form.

3. **TELEGRAPHIC MODIFICATION:** Any bidder may modify his/her bid by telegraphic communication at any time prior to the scheduled closing time for recipient of bids, provided such telegraphic communication is received prior to the closing time, and provided further, the Owner is satisfied that a written confirmation of the telegraphic modification over the signature of the bidder was mailed prior to closing time. The telegraphic communication should not reveal the bid price, but should provide the addition or subtraction or other modification so that the final prices or terms will not be known by the Owner until the sealed bid is opened. If written confirmation is not received within two days from the closing time, no consideration will be given to the telegraphic modification.

4. **METHOD OF BIDDING:** The Owner invites unit price/lump sum price bids as indicated in the Bid Form. If the lowest responsive bid received exceeds the amount of funds available to finance the contract, the Owner may:
- a) Reject all bids;
 - b) Augment the funds available in an amount sufficient to enable award to the lowest responsive bidder or bidders; and
 - c) Take the base bid less a number of items as listed on the proposal form as to produce a net amount which is within available funds.

IF THE LOWEST RESPONSIVE BIDDER IS ABOVE 10% OF THE ESTIMATE, ALL BIDS MUST BE REJECTED.

The estimate on this project is: _____.

Maximum allowable bid is: **\$267,120**

5. **QUALIFICATIONS OF BIDDER:** The Owner may make such investigations as he/she deems necessary to determine the ability of the bidder to perform the work, and the bidder shall furnish to the Owner all such information and data for this purpose as the Owner may request. The Owner reserves the right to reject any bid if the evidence submitted by, or investigation of, such bidder fails to satisfy the Owner that such bidder is properly qualified to carry out the obligations of the contract and to complete the work contemplated therein. Conditional bids will not be accepted. Past performance will be an evaluation criterion. Attention is called to Attachment A: "QUALITATIVE and RESPONSIBLE" CONTRACTOR CRITERIA
6. **BID SECURITY:** Each bid must be accompanied by cash, certified check of the bidder in the amount of 10% of the bid, or a bid bond prepared on the form entitled bid bond attached hereto, duly executed by the bidder as principal and having as surety thereon a surety company approved by the Owner.
- Such cash, checks or bid bonds will be returned to all except the three lowest bidders within three days after the opening of the bids, and the remaining cash, checks or bid bonds will be returned promptly after the Owner and the accepted bidder have executed the contract, or, if no award has been made within ninety (90) days after the date of the opening of bids, upon demand of the bidder at any time thereafter, so long as he/she has not been notified of the acceptance of his/her bid. Attorneys-in-fact who sign bid bonds or contract bonds must file with each bond a certified and effectively dated copy of their power of attorney.
7. **LIQUIDATED DAMAGES FOR FAILURE TO ENTER INTO CONTRACT:** The successful bidder, upon his/her failure or refusal to execute and deliver the contract and bonds required within ten (10) days after he/she has received acceptance of his/her bid, shall forfeit to the Owner, as liquidated damages for such failure or refusal, the security deposited with his/her bid.
8. **CONDITIONS OF WORK:** Each bidder must inform himself/herself fully to the conditions relating to the construction of the project and the employment of labor thereon. Failure to do so will not relieve a successful bidder of his/her obligation to furnish all material and labor necessary to carry out the provisions of his/her contract. Insofar as possible, the contractor in carrying out the work, must employ such methods or means as will not cause any interruption of or interference with the work of any other contractor.
9. **OBLIGATION OF BIDDER:** At the time of the opening of bids, each bidder will be presumed to have inspected the site and to have read and to be thoroughly familiar with the plans and contract documents (including all addenda). The failure or omission of any bidder to examine any form, instrument or document shall in no way relieve any bidder from any obligation in respect of his/her bid.

10. **EXAMINATION OF SITE:** Each bidder shall, and is hereby directed to inspect the entire site of the proposed work and judge for himself/herself as to all the circumstances affecting the cost and progress of the work and shall assume all patent and latent risks in connection herewith.
11. **SOIL CONDITIONS:** Subject to the convenience of the Owners, prospective bidders will be permitted to explore the site by making borings or digging test pits. In such event, the work shall be done at the sole expense and risk of the bidder, and he/she shall maintain and restore the site to original condition.

The Owner does not guarantee the accuracy of any information or samples which it may have obtained from test borings or otherwise as to the kind or condition of the soil that may be encountered in the prosecution of the proposed work, neither does the Owner represent that the plans and specifications drawn are based upon any data so obtained. The Owner does not make any representation as to the soil which may be encountered or of soil or water which underlies the work or is adjacent thereto, including any difficulties that may be due to quicksand, or other unfavorable conditions that may be encountered in the work, whether apparent upon surface inspection or disclosed in the process of carrying forward the work.

12. **WORKING FACILITIES:** The plans/work specifications show, in the general manner, the existing structures and land available for construction purposes. The bidders must satisfy themselves of the conditions and difficulties that may be encountered in the execution of the work at this site.
13. **ADDENDA AND INTERPRETATIONS:** No official interpretation of the meaning of the plans, specifications or other pre-bid documents will be made to any bidder orally. Every request for such interpretation should be in writing addressed to Hocking Athens Perry Community Action and to be given consideration, must be received at least five (5) days prior to the date fixed for the opening of the bids. Any and all such interpretations and any supplemental instructions will be in the form of written addenda to the specifications which, if issued, will be mailed by certified mail or faxed with return receipt requested in both instances to all prospective bidders (at the respective addresses furnished for such purposes), not later than three (3) days prior to the date fixed for the opening of bids. Failure of any bidder to receive any such addendum or interpretation shall not relieve such bidder from any obligation under his/her bid as submitted. All addenda so issued shall become part of the contract documents.
14. **WATER SUPPLY:** All water for construction purposes, as well as the expense of having water conveyed about the work, must be provided by the Contractor and the cost of this work shall be included in the unit prices stipulated for the various items of the work to be done under this contract. The source, quality and quantity of water furnished shall, at all times, be satisfactory to the Engineer and/or Owner or their representatives.
15. **SIGNATURE OF BIDDERS:** The firm, corporate or individual name of the bidder must be signed in ink in the space provided for the signatures on the proposed blanks. In case of a corporation, the title of the officer signing must be stated and such officer must be thereunto duly authorized and the seal of said corporation duly affixed. In the case of a partnership, the signature of at least one of the partners must follow the firm name, using the term "member of the firm". In the case of an individual, use the terms "doing business as", or "sole owner". The bidder shall further state, in his proposal, the name and address of each person or corporation interested therein.
16. **NOTICE OF SPECIAL CONDITIONS:** Attention of the bidder is particularly called to those parts of the General Contract Conditions (Section C) and other contract documents and specifications which deal with the following:
- a) Insurance requirements
 - b) Federal Labor Standards Provisions, including Davis-Bacon wage rates
 - c) Requirement for a payment bond and performance bond for 100% of contract price

- d) Requirement that all subcontractors be approved by the Owner
- e) Time-for-completion and liquidated damages requirements
- f) Safety standards
- g) Contractor's responsibility to obtain permits
- h) Affirmative Action and Equal Opportunity provisions

17. **ADDITIONAL OBLIGATIONS UPON CONTRACT AWARD:** Upon award of the contract, but prior to execution of the final agreement and notice to proceed, the contractor shall submit all of the following documents, completed as required:

- a) Acceptance of Notice of Award
- b) Contract
- c) Insurance certificate(s) and/or policy(ies), including Bureau of Workers' Compensation documentation
- d) Performance bond
- e) Certification of Bidder Regarding Section 3 and Segregated Facilities
- f) Certification(s) of (all) Proposed Subcontractors Regarding Section 3 and Segregated Facilities
- g) Contractor's Certification concerning Labor Standards and Prevailing Wage Requirements
- h) (All) Subcontractor's Certification(s) concerning Labor Standards and Prevailing Wage Requirements.
- i) ALL OF THE FOLLOWING IF CONTRACT EXCEEDS \$10,000.00:
 - Contractor's Section 3 Plan
 - Certification of Bidder Regarding Equal Employment Opportunity
 - Certification(s) by (all) Proposed Subcontractors regarding Equal Employment Opportunity
 - Certification by Contractor and Subcontractors of Compliance with Air and Water Acts

18. **FOREIGN CORPORATIONS AND CONTRACTORS**

A. Foreign Corporations

Definition: "Foreign Corporation" means a corporation incorporated under the laws of another state. No contract shall be entered into with a foreign corporation until the Secretary of State has certified that such corporation is authorized to do business in Ohio; and until, if the bidder so awarded the Contract is a person or partnership, it has filed with the Secretary of State Power of Attorney designating the Secretary of State as its agent for the purpose of accepting service of summons in any action brought under Section 153.05 of the Ohio Revised Code or under Sections 4123.01 to 4123.94, inclusive of the Revised Code.

Attachment A

ADDING "QUALITATIVE and RESPONSIBLE" CONTRACTOR CRITERIA TO THE INVITATION TO BID ON ALL CONSTRUCTION PROJECTS SUBJECT TO PREVAILING WAGE THRESHOLD STANDARDS

WHEREAS, the _____ County Board of Commissioners wish to add "Qualitative and Responsible" contractor criteria to the Invitation to Bid for _____ "County Appropriated" construction projects.

WHEREAS, the Commissioners desire to further ensure that the County's contractors are compliant with the law, financially stable, and capable of executing construction contracts in a competent and professional manner; and

WHEREAS, the Commissioners desire to help ensure the opportunity for workers in _____ County to obtain health insurance and pension benefits so desperately needed in today's society as well as the proper training to maintain a quality workforce

WHEREAS, the "Qualitative and Responsible" criteria enumerated in the attached document will be appropriately included in the _____ County Invitation to Bid for construction projects.

BE IT RESOLVED BY THE _____ COUNTY COMMISSIONERS

That the "Qualitative and Responsible" criteria enumerated are hereby approved and will be added to the _____ County Invitation to Bid for construction projects managed by the _____ County Commissioners

1. Before any contracts are awarded for any construction work within the jurisdiction of the _____ County Commissioners they shall, or their agent shall, hold with the apparent "Low" bidder a "Compliance of Scope" Review. This to verify that bidder is in compliance with this resolution and that all required work under contract is included in bid.
2. The "Low" Bidder whose bid is more than twenty percent (20%) below the next lowest bidder shall list three (3) projects that are each within seventy-five percent (75%) of the bid project estimate for similar projects and that were successfully completed by the bidder not more than five (5) years ago. This information shall be provided, if necessary, at the post-bid "Compliance of Scope Review"
3. Any low bidder shall also be prepared to substantiate their cost over-run and job completion timeliness record. This information shall be provided, at the post-bid "Compliance of Scope" Review
4. The successful bidder shall certify that they will employ "qualified craft workers" with the experience and continuity befitting the wages they will be paid and hired from the labor pool. They possess and maintain any appropriate state licenses.
5. The successful bidder must certify that they have not been penalized or debarred from any public contract for falsified certified payroll records or any other violation of the Fair Labor Standards Act in the last five (5) years.
6. The successful bidder must not be debarred from any public contracts or found by the state (after all appeals) to have violated prevailing wage laws in the last 5 years.
7. The successful bidder must certify that they have implemented a drug free workplace policy.
8. The successful bidder must certify they will secure any required bonds from a surety, licensed to do business in the State of Ohio with an A.M. Best Company rating of at least "A".
9. The successful bidder must certify that they have complied with unemployment and worker's compensation laws for at least the nine months preceding the date of bid submittal
10. The successful bidder must certify that they provide a minimum health care plan for those employees that will be working on the proposed project.
11. The successful bidder must certify that they provide a pension or retirement program for those employees that will be working on the proposed project.
12. The successful bidder must submit a list of sub-contractors to be used on the project or before notice to proceed is issued.
13. The successful bidder must certify that their construction license has not been revoked in any state or municipality.

GENERAL CONTRACT CONDITIONS

SECTION C

ARTICLE 1 - CONTRACT AND CONTRACT DOCUMENTS

- A. The project to be constructed pursuant to this contract will be financed with assistance from the Department of Housing and Urban Development and is subject to all applicable Federal laws and regulations.
- B. All applicable State laws, municipal ordinances, and the rules and regulations of all authorities having jurisdiction over construction of the project shall apply to the contract throughout, and they will be deemed to be included in the contract the same as though herein written out in full.
- C. The Plans, Specifications and Addenda, hereinafter enumerated in Paragraph 1 of the Supplemental General Conditions shall form part of this Contract and provisions thereof shall be as binding upon the parties hereto as if they were herein fully set forth. The table of contents, titles, headings, running headlines and marginal notes contained herein and in said documents are solely to facilitate reference to various provisions of the Contract Documents and in no way affect, limit or cast light on the interpretation of the provisions to which they refer.

ARTICLE 2 - PERFORMANCE AND PAYMENT BONDS

Simultaneously with his/her delivery of the executed contract, the Contractor shall furnish a surety bond or bonds as security for faithful performance of this contract and for the payment of all persons performing labor on the project under this Contract and furnishing materials in connection with this contract, as specified in the General Conditions included herein. The surety on such bond or bonds shall be a duly authorized surety company satisfactory to the Owner. The bond shall be for 100 percent of the contract price. A Payment Bond and Performance Bond are required per regulations below:

A state or local unit of government receiving a grant from the Federal government which requires contracting for construction of facility improvement shall follow its own requirement relating to bid guarantees, performance bonds, and payment bonds, except for contracts or subcontracts exceeding \$100,000.00. For contracts or subcontracts exceeding \$100,000.00, the Federal agency may accept the bonding policy requirement of the grantee provided the Federal agency has made a determination that the Government's interest in adequately protected. If such a determination has not been made, the minimum requirements shall be as follows:

- A. *A bid guaranty from each bidder equivalent to ten percent of the proposal price. The "bid guarantee" shall consist of a firm commitment such as a bid bond, certified check, or other negotiable instrument accompanying a proposal as assurance that the bidder will, upon acceptance of his/her proposal, execute such contractual documents as may be required within the time specified.*
- B. *A performance bond on the part of the contractor for 100 percent of the contract price. A "performance bond" is one executed in connection with a contract to secure fulfillment of all the contractor's obligations under such contract.*
- C. *A payment bond on the part of the contractor for 100 percent of the contract price. A "payment bond" is one executed in connection with a contract to assure payment as required by law of all persons supplying labor and material in the execution of the work provided for in the contract.*

Attorneys-in-fact who sign bid bonds or contract bonds must file with each bond a certified and effectively dated copy of their power of attorney. Under certain conditions, and within the limits of State and local laws and regulations, the Owner may waive the requirement that the Payment and Performance Bond be underwritten by a surety company and may authorize in lieu thereof, a personal bond backed by a letter of credit from a local lending institution for the full value of the Contract.

ARTICLE 3 - WAGE RATES

In the event that the rate of wages paid for any trade or occupant in the locality where such work is being performed are under current collective agreements or understandings between bona fide organizations of labor and employer, then the wages to be paid shall be not less than such agreed wage rates, nor less than the minimum rates compiled by the Federal Labor Standard Provision. A copy of these prevailing rates of wages has been included in these specifications.

Every Contractor and Subcontractor who is subject to this contract shall, as soon as he/she begins performance under his/her contract with the Owner, supply the Owner a schedule of dates on which he/she is required to pay wages to employees. He/She shall also deliver to the prevailing wage coordinator within three weeks after each pay date, a certified copy of his/her payroll which shall exhibit for each employee paid any wages, name, current address, social security number, number of hours worked each day of the pay period and total for each week, hourly rate of pay, job classification, fringe payments, and deductions from wages. The certification of each payroll shall be executed by the Contractor, Subcontractor, or duly executed by the Contractor, Subcontractor, or duly appointed agent thereof and shall recite that the payroll is correct and complete and that the wage rate shown is not less than those required by the contract. **Insofar as possible, local labor shall be employed on this project.**

ARTICLE 4 - AFFIRMATIVE ACTION

Each bidder, Contractor, and/or Subcontractor, must fully comply with either Part 1 or Part 11, as applicable, of Executive Order 1246 as stated during the performance of this contract or subcontract. The Contractor commits itself to the goals for minority manpower utilization in either Part 1 or Part 11, as applicable, and all other requirements, terms and conditions of those proposal conditions by submitting a properly signed bid.

The Contractor shall appoint a company executive to assume the responsibility for the implementation of the requirements, terms and conditions of these bid conditions.

ARTICLE 5 - INSURANCE

- A. The Contractor shall not commence work under this Contract until he has obtained all the insurance required hereunder and such insurance has been approved by the Owner, nor shall the Contractor allow any Subcontractor to commence work on his subcontract until all similar insurance required of the Subcontractor has been so obtained and approved. Approval of the insurance by the Owner shall not relieve or decrease the liability of the Contractor hereunder.
- B. The Contractor shall file with the Owner all Certificate(s) of Insurance as are necessary to document the insurance coverage required hereunder, subject to the approval of the Owner and receipt of any additional forms/documentation requested, prior to final execution of the Agreement Contract and issuance of the Notice to Proceed.
- C. Worker's Compensation
 - a) All contractors and subcontractors shall acquire and maintain, during the term of the Contract, Worker's Compensation insurance in full compliance with the laws of the State of Ohio.

D. Contractor's Liability Insurance

- a) The Contractor shall acquire and maintain during the term of the Contract Bodily Injury and Property Damage Liability Insurance under a standard Comprehensive General/Automobile Liability Policy which shall provide and include coverage on all Contractor's Operations, Contractor's Protective (Sublet) Liability, Contractual Liability, Completed Operations Liability, Owned Automobiles and Non-owned and Hired Automobiles.
- b) Property Damage Liability Insurance shall be provided on any demolition, blasting, excavating, shoring or similar operation on an "if any" basis.
- c) Bodily Injury Liability limits shall be for an amount of no less than Two Hundred Fifty Thousand (\$250,000) Dollars for injuries, including wrongful death to any one person and subject to the same limit for each person, in an amount of not less than Five Hundred Thousand (\$500,000) Dollars on the account of any one occurrence.
- d) Property Damage Liability insurance shall be in an amount of not less than One Hundred Thousand (\$100,000) per occurrence. General Liability shall be extended to provide "Broad Form Property Damage Liability," and in an amount of not less than One Million (\$1,000,000) Dollars aggregate for damage on account of all occurrences.
- e) Any combination of underlying Comprehensive General/Automobile Liability coverage with Umbrella/Excess Liability coverage which provides no less than One Million (\$1,000,000) Dollars Single Limit Bodily Injury and Property Damage Liability Insurance for the Contractor will also be acceptable.
- f) The Owner may adjust the liability limits to coincide with local government procurement policies and practice within the limits of state and local law.

E. Builder's Risk Insurance

- a) Each Contractor shall maintain insurance from loss incurred by fire, lightning, extended coverage hazards, vandalism, theft, explosion and malicious mischief in the full amount of the Contract and such insurance shall cover all labor and material connected with the work, including materials delivered to the site, but not yet installed. This insurance shall be project specific and valued in the full amount of the contract.

F. Installation Floater Insurance

- a) When a contractor is involved solely in the installation of materials and not in the construction of a building (i.e. plumbing), an Installation Floater is required in lieu of a Builder's Risk Policy with the same general conditions applying as set forth in Paragraph E.

G. The Policies as listed above shall all contain all the following special provisions:

- a) The Company agrees that thirty (30) days prior to cancellation or reduction of the insurance afforded by this policy with respect to the Contract involved, written notice will be mailed to HOCKING ATHENS PERRY COMMUNITY ACTION AGENCY.
- b) The maintaining of such insurance as outlined herein shall in no way constitute a waiver of legal liability for damage to any adjoining buildings or their contents or the work and property of others on the site beyond the limits of insurance thus maintained. The Contractor shall hold the Owner free and harmless from any injury and damage resulting from the negligent or faulty performance of the Contract by the Contractor or by his/her Subcontractors.

- c) Each Contractor shall hold the Owner harmless from all payments for patents, either as royalty or otherwise, in the use of materials, methods, appliances, etc., that he may be any way involved in or connected with any part of his work or the work of his Subcontractors.
- d) Prior to commencement of any work under the Contract, the Contractor shall furnish one (1) copy of Declaration of Insurance as evidence of coverage.

ARTICLE 6 - SAFETY

- A. The Contractor will be responsible for initiating, maintaining and supervising all safety precautions and program in connection with the Work. He/She will take all necessary precautions for the safety of, and will provide the necessary protection to prevent damage, injury, or loss to all employees on the work and other persons who may be affected thereby, and all the work and all materials or equipment to be incorporated therein, whether in storage on or off the site, and other property at the site or adjacent thereto, including trees, shrubs, lawns, walks, pavements, roadways, structures, and utilities not designated form removal, relocation, or replacement in the course of construction.
- B. The Contractor will erect and maintain, as required by the conditions and progress of the Work, all necessary safeguards for safety protection. He/She will notify owners of adjacent utilities when prosecution of the work may affect them.
- C. The Contractor shall comply with the safety standards guidelines provisions of applicable laws, building and construction codes as well as the requirements of the Occupational Safety and Health Act of 1970, as amended through January 1, 2004, and the requirements of Title 29 of the Code of Federal Regulations. The Chapter shall also comply with Chapter 4104.9-2 of the Ohio Revised Code prohibiting the Employment of Minors in Occupations Hazardous or Detrimental to their health and OSHA Part 1926, Safety and Health Regulations for Construction.
- D. The Contractor shall maintain at his/her office or other well-known place at the job site, all articles necessary for giving first aid to the injured, and shall make standing arrangements for the immediate removal to a hospital or a doctor's car of persons (including employees) who may be injured at the job site. In no case shall employees be permitted to work at a job site before the employer has made a standing arrangement for removal of injured persons to a hospital or a doctor's care.
- E. Lights, signs and barricades shall be used to maintain traffic and safety for vehicular and pedestrian traffic during the course of this contract in accordance with the specifications.

ARTICLE 7 - PERMITS

The Owner is responsible for obtaining and paying for the following permits: _____
_____. (If blank, contractor is responsible for all permitting necessary.)

The Contractor is responsible for obtaining and paying for all other necessary permits and licenses from the proper authorities. The Contractor shall give all notices and comply with all laws, ordinances, rules, and regulations bearing on the conduct of the work as drawn and specified. If the Contractor observes that the Contract Documents are at variance therewith, he/she shall promptly notify the Owner in writing.

ARTICLE 8 - SUPERVISION

- A. The Contractor will supervise and direct the work. He/She will be solely responsible for the means, methods, techniques, sequences, and procedures of construction. The Contractor will employ and maintain on the work site a qualified supervisor or superintendent who shall have been designated in writing by the Contractor at the pre-construction meeting as the Contractor's representative at the site. The Supervisor shall have full authority to act on behalf of the Contractor and communications given to the supervisor shall be as binding as if given to the Contractor. The supervisor shall be present and on the site at all times as required to perform adequate supervision and coordination of the work.
- B. The Owner and its representative will, at all times, have access to the work. In addition, authorized representatives and agents of any participating federal or state agency shall be permitted to inspect all work, materials, and payrolls, records of personnel, invoices of materials, and other relevant data and records. The Contractor will provide proper facilities for such access and observation of the work and also for any inspection or testing thereof.
- C. The Contractor shall submit a proposed program of operation, showing clearly how he/she proposed to conduct the work as to bring about the completion of his/her work within the time limit specified. This program shall outline the proposed sequence of operations, the rates of progress and the dates when his/her work will be sufficiently advanced to permit the installation of the work under other contract, and the estimated progress payments due under the Contract. The work under this contract shall be so scheduled that as structures are completed, they can be placed into useful operation with a minimum of delay. The program shall be subject to the approval of the Owner.
- D. All construction as proposed along all City, Township, County, State and Federal roads including storage and stockpiling of materials, is to be conducted within the limits of the public right-of-way. Bracing, sheeting and shoring shall be used to keep all construction work within the construction limits unless work agreements are secured from the adjacent property owners. It is the Contractor's responsibility to secure these work agreements, if deemed necessary. Copies of the work agreements shall be delivered to the Engineer and the Owner prior to any work beginning on the affected property.

ARTICLE 9 - CLAIMS AGAINST CONTRACTOR

The Contractor shall indemnify and save the Owner or the Owner's agents harmless from all claims growing out of the lawful demands of Subcontractor's laborers, workmen, mechanics, materialmen, and furnishers of machinery and parts thereof, equipment, tools, and all supplies, incurred in the furtherance of the performance of the work. The Contractor shall, at the Owner's request, furnish satisfactory evidence that all obligations of the nature designated above have been paid, discharged, or waived. If the Contractor fails to do so, the Owner, may, after having notified the Contractor, withhold pay unpaid bills or withhold from the Contractor's unpaid compensation a sum of money deemed reasonably sufficient to pay any all such lawful claims until satisfactory evidence is furnished that all liabilities have been fully discharged whereupon payment to the Contractor shall be resumed, in accordance with the terms of the Contract Documents, but in no event shall the provisions of this sentence be construed to impose any obligations upon the Owner to either the Contractor, his Surety, or any third party. In paying any unpaid bills of the Contractor, any payment so made by the Owner shall be considered as a payment made under the Contract Documents by the Owner to the Contractor and the Owner shall not be liable to the contractor for any such payments in good faith.

ARTICLE 10 - SUBCONTRACTING

- A. Neither the Contractor nor the Owner shall sell, transfer, assign, or otherwise dispose of his right, title, or interest therein, or his obligations thereunder.

- B. The Contractor shall not sublet, sell, transfer or assign any portion of the contract without written consent of the Owner of his/her designated agent. When such consent is given, the Contractor will be permitted to sublet a portion thereof, but shall perform with his/her own organization, work amounting to no less than fifty percent of the total contract cost, except that any item designated in the contract before computing the amount of work required to be performed by the Contractor with his/her own organization. No subcontract, or transfer of contract, shall in any way release the Contractor of his/her liability under the contract and bonds.
- C. The Contractor shall not award work to Subcontractor(s) without prior written approval of the Owner, after verification by the Ohio Department of Development of the subcontractor's current eligibility status, and after submission of all certifications as required in

INSTRUCTIONS TO BIDDERS. The Contractor shall be fully responsible to the Owner for the acts and omissions of the subcontractor(s), and of the persons either directly or indirectly employed by them, as he is for the acts and omissions of persons directly employed by him/her.

ARTICLE 11 - CHANGE OF WORK

- A. The Owner reserves the right to make, at any time during the progress of the work, such increases or decreases in quantities and such alterations in details of work as may be deemed necessary or desirable. Such increases or decreases and alterations shall not invalidate the contractor nor release the surety, the Contractor agrees to perform the work as altered, the same as if it had been a part of the original contract.
- B. Authorized alterations in plans or quantities of work involving work not covered by unit prices in the proposal are paid for as stipulated in the change order authorizing such work.
- C. No changes in work covered by the approved Contract shall be made without having prior written approval of the Owner.

ARTICLE 12 - TIME

- A. The Date of beginning and time for completion of the work are essential conditions of the Contract Documents and work embraced shall be commenced on a date specified in the Notice to Proceed.
- B. The Contractor will proceed with the work at such rate of progress to ensure full completion within the Contract Time. It is expressly understood and agreed, by and between the Contractor and the Owner, that the Contract Time for the completion of the work described herein is a reasonable time, taking into consideration the average climatic and economic conditions and other factors prevailing in the locality of the work.
- C. The Contract Time to fully complete the project shall be _____consecutive calendar days following the date of commencement of work to be specified in a written "Notice to Proceed".
- D. If the Contractor shall fail to complete the work within the Contract Time, and an extension of time is not granted by the Owner, the Contractor will pay the Owner for liquidated damages \$100.00 for each calendar day that the Contractor shall be in default after the time stipulated in the Contract Documents.

ARTICLE 13 - COMPLETION OF WORK

- A. The Contractor shall guarantee all materials and equipment furnished and work performed for a period of one year from the date of Substantial Completion. The Contractor warrants and guarantees for a period of one year from the date of Substantial Completion of the improvement that it is free from all defects due to faulty materials or workmanship, and the Contractor shall promptly make corrections as may be

necessary by reason of such defects. The Owner will give notice of observed defects with reasonable promptness. In the event that the Contractor should fail to make repairs, adjustments, or other work which may be made necessary by such defects, the Owner may do so and charge the Contractor the cost thereby incurred. The Contract Bond shall remain in full force and effect through the guarantee period.

- B. When the work, including that performed by Subcontractors, is completed, the site shall be cleaned of all rubbish and debris caused by the construction. All sheds or other temporary structures, surplus materials, and equipment shall be removed and the project left in a neat and presentable condition.

ARTICLE 14 - TERMINATION

After ten (10) days from delivery of a Written Notice to the Contractor, the Owner may, without cause and without prejudice to any other right or remedy, elect to terminate the Contract. In such case, the Contractor shall be paid for all work executed and any expense sustained plus reasonable profit, unless such termination was due to the act or conduct of the Contractor.

ARTICLE 15 - PAYMENT

Payment to the Contractor shall be made by the Owner as follows: **100% upon completion or in draws of approximately 50%. Payment will be made only on work that is complete.** The Owner's Representative shall certify on the pay request that he approved the completed work prior to the Owner making payment. Upon receipt of an approved invoice from the Contractor, the Owner shall submit a drawdown request to the Ohio Department of Development for CDBG funds to pay the Contractor. A turnaround time of 30 - 45 days is expected before said funds are forwarded to the Owner.

SUPPLEMENTAL GENERAL CONDITIONS

1. ENUMERATION OF PLANS, SPECIFICATIONS AND ADDENDA

Following are the Plans, Specifications and an Addenda which form a part of this contract, as set forth in Article I of the General Contract Conditions, "Contract and Contract Document".

Drawings	Number	Date
<hr/>		
Specifications	Number	Date
<hr/>		
Addenda	Number	Date
<hr/>		

2. STATED ALLOWANCES

The Contractor shall include the following cash allowances in his proposal:

3. SPECIAL HAZARDS

4. CONTRACTOR'S AND SUBCONTRACTOR'S PUBLIC LIABILITY, VEHICLE LIABILITY, AND PROPERTY DAMAGE INSURANCE

- a. As required under Article 5 of the General Contract Conditions, the Contractor's Public Liability Insurance and Vehicle Liability Insurance shall be in an amount not less than \$1,000,000 for injuries, including accidental death, to any one person, and subject to the same limit for each person in an amount not less than \$500,000 on account of one accident, and Contractor's Property Damage Insurance in an amount not less than \$1,000,000.
- b. The Contractor shall either (1) require each of his subcontractors to procure and to maintain during the life of his subcontract, Subcontractor's Public Liability and Property Damage of the type and in the same amount as specified in the preceding paragraph, or (2) insure the activities of his subcontractors in his own policy.

5. PHOTOGRAPHS OF THE PROJECT

The Contractor will furnish photographs in the number, type and state as enumerated below:

6. SCHEDULE OF FEDERAL OCCUPATIONAL CLASSIFICATIONS AND DAVIS-BACON MINIMUM HOURLY WAGE RATES

Refer to Section E

WORK SPECIFICATIONS

SECTION D

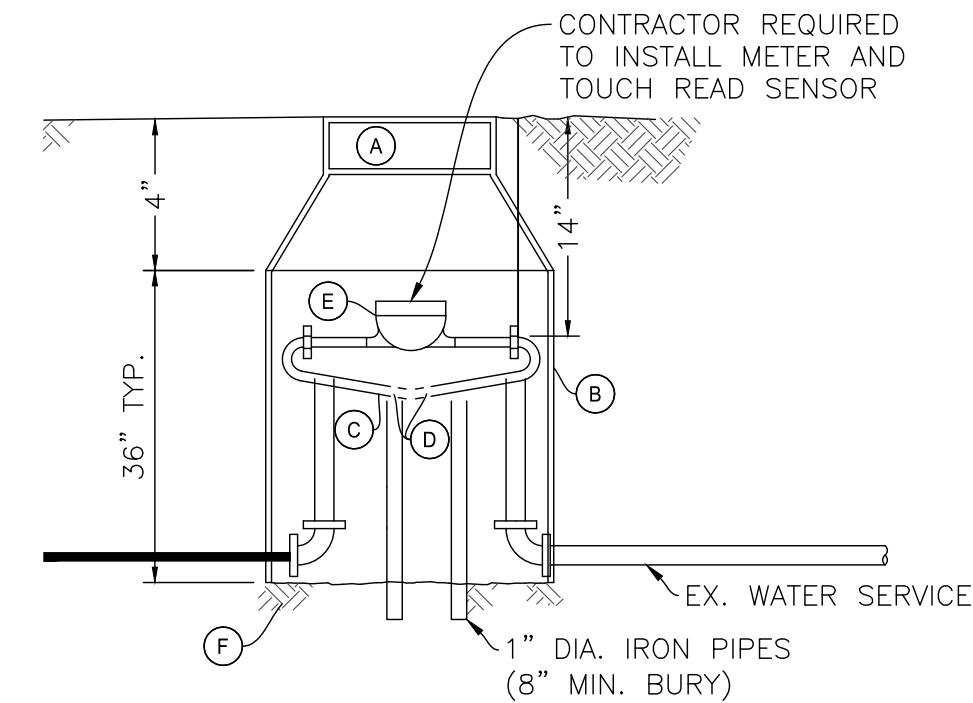

- (A) 1 FORD METER BOX COMPANY TYPE A SINGLE LID COVER A32-T OR APPROVED EQUIVALENT. TOUCH READ SENSOR INSTALLED IN LID.
- (B) 2 OLD CASTLE PRECAST CARSON BRAND ROUND 18"x36" PLASTIC HEAVY WALL METER PIT OR APPROVED EQUIVALENT.
- (C) 3 5/8" METER SETTING, FORD 70 SERIES COPPER VBHH71-21W-66-33-NL OR APPROVED EQUIVALENT.
- (D) 4 CLAMP METER INLET & OUTLET PIPES TO IRON ANGLES. TO ALLOW CLEARANCE FOR METER, IRON ANGLES SHALL EXTEND NO MORE THAN 1" ABOVE THE PIPES.
- (E) 5 SENSUS 5/8" SR METER WITH TOUCH READ SENSOR.
- (F) 6 BACKFILL COMPACTED PRIOR TO SETTING

DETAIL NOTES:

- THE WATER SERVICE LINE SHALL BE BEDDED USING # 57 GRAVEL. COST TO BE INCLUDED IN THE UNIT BID PRICE FOR METER PIT RELOCATIONS.
- HAVE THE TOP SET AT FINISHED GRADE
- ALL EXCAVATIONS WITHIN 5' OF A PAVED OR GRAVEL SURFACE WILL REQUIRE ODOT ITEM #304 AGGREGATE BASE FOR BACKFILL. COST TO BE INCLUDED IN THE UNIT BID PRICE FOR METER PIT RELOCATIONS.
- ALL SIDEWALK AND PAVEMENT AREAS DAMAGED WILL NEED TO BE RESTORED TO ORIGINAL CONDITION.
- ALL GRASS OR LAWN AREAS SHALL BE RESTORED IN ACCORDANCE WITH ODOT ITEM 659 SEEDING AND MULCHING.

NOTES:

- NEW METER PIT COMPLETE SHALL INCLUDE THE FOLLOWING: EXCAVATION, BEDDING, BACKFILL, METER PIT, METER PIT LID, METER SETTER, METER, TOUCH READ SENSOR, MISC. FITTINGS TO CONNECT TO EXISTING WATER SERVICE, FINAL GRADING AND SEEDING, SIDEWALK REPAIR AND/OR PAVEMENT REPAIR.
- REMOVE EXISTING METER PIT SHALL INCLUDE EXCAVATION, BACKFILL, REMOVAL OF EX. METER PIT, METER PIT LID, METER, METER SETTER AND TOUCH READ SENSOR, FINAL GRADING AND SEEDING, SIDEWALK REPAIR AND/OR PAVEMENT REPAIR.
- EXISTING WATER SYSTEM MATERIALS REMOVED OR ABANDONED BY DURING THIS PROJECT SHALL REMAIN THE PROPERTY OF THE VILLAGE OF MURRAY CITY & SHALL BE DELIVERED TO A SITE DETERMINED BY THE VILLAGE OF MURRAY CITY. ANY MATERIALS REMOVED THAT IS UNDESIRABLE TO THE VILLAGE SHALL BE DISPOSED OF BY THE CONTRACTOR. THE COST TO BE INCLUDED IN BID PRICE.
- A TOTAL OF 210 METER PITS ARE TO BE REPLACED. A CUSTOMER LIST WILL BE PROVIDED TO CONTRACTOR AT THE TIME OF CONSTRUCTION.
- ALL WATER SERVICES ARE LOCATED WITHIN THE VILLAGE LIMITS.
- AS A PART OF THE BID PRICE, THE CONTRACTOR SHALL PROVIDE A SENSUS TOUCH READ WAND, SOFTWARE INSTALLATION AND 8 HOURS OF TRAINING ON THE VILLAGE'S COMPUTER SYSTEM.

TYPICAL 3/4" STANDARD WATER SERVICE W/ METER BOX

NOT TO SCALE

1

APPROVED PLANS: THE CIVIL/SITE DRAWINGS PREPARED BY SANDS DECKER FOR THIS PROJECT ARE **NOT FOR CONSTRUCTION** UNLESS AND UNTIL ALL APPLICABLE APPROVALS HAVE BEEN SECURED AND THE DRAWINGS ARE ISSUED FOR CONSTRUCTION. LAYOUT, FABRICATION OF MATERIALS, CONSTRUCTION, OR ANY CONSTRUCTION-RELATED ACTIVITIES ASSOCIATED WITH THESE DRAWINGS IS NOT TO PROCEED UNLESS EACH SHEET INCLUDES THE **ISSUED FOR CONSTRUCTION** LABEL.

GENERAL: THE CURRENT STATE OF OHIO, DEPARTMENT OF TRANSPORTATION CONSTRUCTION & MATERIAL SPECIFICATIONS (ODOTCMS) TOGETHER WITH THE REQUIREMENTS OF HOCKING COUNTY, INCLUDING ALL SUPPLEMENTS THERETO, IN FORCE ON THE DATE OF CONTRACT, SHALL GOVERN ALL MATERIALS & WORKMANSHIP INVOLVED IN THE IMPROVEMENTS SHOWN ON THESE PLANS. WHEN THERE IS OR APPEARS TO BE A CONFLICT BETWEEN THE ABOVE REFERENCED SPECIFICATIONS & THESE PLANS, THE MOST STRINGENT REQUIREMENT SHALL GOVERN. UNLESS OTHERWISE SPECIFIED, ALL ITEM NUMBERS REFER TO ODOTCMS.

PROJECT LIMITS: THE CONTRACTOR SHALL CONFINE HIS ACTIVITIES TO THE PROJECT SITE UNDER DEVELOPMENT, THE EXISTING RIGHTS-OF-WAY, CONSTRUCTION EASEMENTS & PERMANENT EASEMENTS, & SHALL NOT TRESPASS UPON PRIVATE PROPERTY WITHOUT WRITTEN CONSENT OF THE PROPERTY OWNER.

PROTECTION OF SURVEY MONUMENTS: THE CONTRACTOR SHALL CAREFULLY PRESERVE BENCHMARKS, PROPERTY CORNERS, REFERENCE POINTS, & ANY OTHER SURVEY MONUMENTS OR MARKERS. IF THE ACTIONS OF THE CONTRACTOR, HIS EMPLOYEES, OR HIS SUB-CONTRACTORS RESULT IN DESTRUCTION OF OR DAMAGE TO ANY OF THE ABOVE ITEMS, THOSE ITEMS SHALL BE ACCURATELY RESTORED, AT THE CONTRACTOR'S EXPENSE, BY A LICENSED SURVEYOR REGISTERED IN THE STATE OF OHIO.

MISCELLANEOUS WORK: ALL ITEMS OF WORK CALLED FOR ON THE PLANS FOR WHICH NO SPECIFIC METHOD OF PAYMENT IS PROVIDED SHALL BE PERFORMED BY THE CONTRACTOR & THE COST OF SAME SHALL BE INCLUDED IN THE PRICE BID FOR THE VARIOUS RELATED ITEMS.

PERMITS: THE CONTRACTOR SHALL OBTAIN ALL NECESSARY PERMITS UNLESS OTHERWISE INDICATED IN THESE DOCUMENTS.

TRAFFIC CONTROL: THE CONTRACTOR SHALL USE ADEQUATE LIGHTS, SIGNS, FLAGGERS, & BARRICADES AS REQUIRED IN ITEM 614 TO SAFEGUARD THE TRAVELING PUBLIC AT ALL TIMES. ALL TRENCHES SHALL BE BACKFILLED OR SECURELY PLATED DURING NON-WORKING HOURS. WHERE IT IS ANTICIPATED THAT WORK WILL CLOSE A ROAD OR STREET, THE CONTRACTOR SHALL INFORM THE RESIDENTS TO BE AFFECTED, THE LOCAL LAW ENFORCEMENT AGENCY, THE LOCAL FIRE DEPARTMENT, & THE ENGINEER AS TO THE EXTENT, NATURE, & THE TIME OF THE ANTICIPATED WORK. THE CONTRACTOR SHALL SUBMIT A PLAN & SCHEDULE FOR DETOURING TRAFFIC 10 DAYS PRIOR TO THE CLOSING OF ANY ROAD OR STREET TO THE ENGINEER & ROAD OWNER. DURING A CLOSING OF A ROAD OR STREET, THE CONTRACTOR SHALL PROVIDE ACCESS TO PROPERTIES FOR EMERGENCY VEHICLES & THE PROPERTY OWNERS. NO ROAD OR STREET SHALL BE CLOSED UNTIL THE SCHEDULE IS APPROVED BY THE AGENCY HAVING CONTROL OF THE ROAD.

SAFETY OF CONSTRUCTION: THE CONTRACTOR SHALL COMPLY WITH THE FEDERAL OCCUPATIONAL SAFETY & HEALTH ACT OF 1970 (OSHA) & ALL OTHER APPLICABLE FEDERAL, STATE, & LOCAL LAWS, REGULATIONS, FINDINGS & ORDERS RELATING TO SAFETY & HEALTH CONDITIONS ON THE WORK SITE. CONSTRUCTION METHODS FOR COMPLETING THE WORK DESCRIBED IN THESE CONTRACT DOCUMENTS SHALL BE CONSISTENT WITH THE OCCUPATIONAL SAFETY & HEALTH ADMINISTRATION (OSHA) AMENDED CONSTRUCTION STANDARDS FOR EXCAVATIONS, 29 CFR PART 1926, SUB-PART P, EFFECTIVE MARCH 5, 1990.

EROSION & SEDIMENT CONTROL: PROJECTS DISTURBING LESS THAN ONE ACRE & NOT PART OF A LARGER COMMON PLAN OF DEVELOPMENT ARE NOT REQUIRED TO SUBMIT A NOTICE OF INTENT (NOI) TO THE OHIO EPA FOR COVERAGE UNDER THEIR GENERAL CONSTRUCTION STORM WATER PERMIT & ARE NOT REQUIRED TO MAINTAIN A STORM WATER POLLUTION PREVENTION PLAN (SWPP3) ON SITE. THE CONTRACTOR SHALL, HOWEVER, INSTALL & MAINTAIN SILT FENCES, DITCH CHECKS, TEMPORARY SEEDING, & OTHER MEASURES AS NECESSARY TO CONTROL SOIL EROSION & PREVENT SEDIMENT-LADEN RUN-OFF FROM EXITING THE SITE OR ENTERING STORM SEWER SYSTEMS OR DRAINAGE WAYS.

EXISTING UTILITIES: THE INFORMATION SHOWN CONCERNING EXISTING UTILITIES IS APPROXIMATE. THE LOCATION, SIZES, & OTHER INFORMATION SHOWN IS ONLY AS ACCURATE AS THAT PROVIDED ON THE EXISTING SITE SURVEY. THE EXISTING SITE SURVEY WAS PROVIDED BY OTHERS & SANDS DECKER CPS, LLC ASSUMES NO LIABILITY FOR ERRORS OR OMISSIONS THEREIN. THE CONTRACTOR IS RESPONSIBLE TO PHYSICALLY LOCATE & VERIFY, IN THE FIELD, THE HORIZONTAL & VERTICAL LOCATIONS OF ALL EXISTING UTILITIES, WHETHER SHOWN ON THE PLANS OR NOT, PRIOR TO THE BEGINNING OF CONSTRUCTION. THE CONTRACTOR SHALL SUPPORT, PROTECT & RESTORE ALL EXISTING UTILITIES & THEIR ASSOCIATED ITEMS. THE CONTRACTOR SHALL ADHERE TO ALL APPLICABLE SECTIONS OF THE OHIO REVISED CODE INCLUDING SECTIONS 153.64 & 3781.28. THE CONTRACTOR SHALL NOTIFY THE REGISTERED UTILITY PROTECTION SERVICE & ALL UTILITY OWNERS HAVING FACILITIES IN THE CONSTRUCTION AREA WHO ARE NOT MEMBERS OF A REGISTERED UNDERGROUND UTILITY PROTECTION SERVICE. THE CONTRACTOR SHALL GIVE NOTIFICATION AS REQUIRED BY OHIO REVISED CODE, AT LEAST TWO (2) & NOT MORE THAN TEN (10) WORKING DAYS PRIOR TO COMMENCING CONSTRUCTION OPERATIONS, EXCLUDING SATURDAYS, SUNDAYS, & LEGAL HOLIDAYS, & SHALL COORDINATE HIS WORK WITH THE UTILITY OWNERS UNTIL HIS WORK IS COMPLETED. THE CONTRACTOR SHALL KEEP THE UTILITY OWNERS APPRISED OF HIS SCHEDULE & REQUIREMENTS & SHALL PROVIDE THE PROJECT OWNER WITH EVIDENCE OF HAVING NOTIFIED THE UTILITIES & PROVIDED THEM WITH HIS WORK SCHEDULE PRIOR TO BEGINNING ANY WORK.

DRAINAGE TILE: ALL FARM DRAINS, ROADWAY DRAINS, & OTHER DRAINAGE TILE WHICH ARE ENCOUNTED WITHIN THE CONSTRUCTION LIMITS DURING CONSTRUCTION SHALL BE PROVIDED WITH AN UNOBSTRUCTED OUTLET. EXISTING COLLECTOR TILES WHICH ARE LOCATED BELOW THE PROPOSED FINISHED ELEVATION & WHICH CROSS THE TRENCH SHALL BE REPLACED WITHIN THE TRENCH LIMITS BY ITEM 611 CONDUIT. THE LOCATION, TYPE, SIZE, & GRADE OF THE REQUIRED REPLACEMENT SHALL BE DETERMINED BY THE PROJECT ENGINEER OR HIS SITE REPRESENTATIVE DURING CONSTRUCTION. NECESSARY BENDS OR FITTINGS, COMPACTED GRANULAR BACKFILL, & ASSOCIATED ITEMS SHALL BE INCLUDED IN THE BID PRICE.

TEMPORARY PAVEMENT: TEMPORARY PAVEMENT REPLACEMENT SHALL BE PROVIDED ON PERMANENT PAVEMENT DAMAGED OR REMOVED BY THE CONTRACTOR IN THE PERFORMANCE OF THE WORK. AS SOON AS THE TRENCH HAS BEEN BACKFILLED, TEMPORARY PAVEMENT SHALL BE INSTALLED. THE ENGINEER MAY REQUIRE THAT ALL MATERIALS & EQUIPMENT INCIDENTAL TO PROVIDING THE TEMPORARY PAVEMENT BE ON THE JOB SITE PRIOR TO REMOVING THE EXISTING PAVEMENT. TEMPORARY PAVEMENT SHALL CONSIST OF 2" OF BITUMINOUS COLD MIX PLACED UPON 6" OF COMPACTED ITEM 304, AGGREGATE BASE. TEMPORARY PAVEMENT SHALL BE MAINTAINED BY THE CONTRACTOR UNTIL PERMANENT PAVEMENT IS INSTALLED.

PERMANENT PAVEMENT: WHERE DAMAGED OR REMOVED, THE PAVEMENT SHALL BE REPLACED BY FIRST REMOVING TEMPORARY PAVEMENT DOWN TO CLEAN GRANULAR MATERIAL & REMOVING EXISTING PAVEMENT FOR AT LEAST 12" BEYOND THE TRENCH LIMITS ON EACH SIDE. PAVEMENT TO BE REMOVED SHALL BE NEATLY SAWED NOT MORE THAN 72 HOURS PRIOR TO THE PLACING OF PERMANENT PAVEMENT MATERIALS. PERMANENT PAVEMENT REPLACEMENT MATERIALS & WORKMANSHIP SHALL BE AS SHOWN ON THE CONSTRUCTION DRAWINGS. ITEM 407, TACK COAT, SHALL BE APPLIED TO THE EXPOSED EXISTING PAVEMENT EDGES WHEN EITHER THE EXISTING OR NEW PAVEMENT IS BITUMINOUS MATERIAL. WHEN THE PERMANENT PAVEMENT IS BITUMINOUS MATERIAL, ITEM 407, TACK COAT SHALL BE APPLIED TO BITUMINOUS OR CONCRETE BASE MATERIAL PRIOR TO THE PLACING OF THE PERMANENT PAVEMENT.

CONFLICTS IN GRADE: IN ALL CONFLICTS IN GRADE BETWEEN THE WATER LINES OR WATER SERVICES & OTHER EXISTING UTILITIES, THE WATER LINE/SERVICE LINE SHALL BE LOWERED DURING CONSTRUCTION. A MINIMUM 18" VERTICAL & 10' HORIZONTAL CLEARANCE SHALL BE MAINTAINED BETWEEN THE WATER LINE & ANY SANITARY OR STORM SEWER. 12" MINIMUM VERTICAL CLEARANCE FOR OTHER UTILITIES. THE CONTRACTOR SHALL VERIFY LOCATIONS OF EXISTING UTILITIES AHEAD OF HIS CONSTRUCTION OPERATIONS TO ALLOW FOR ADJUSTMENTS IN GRADE TO THE WATER LINE THAT MAY BE REQUIRED AS A RESULT OF POTENTIAL CONFLICTS WITH AN EXISTING UTILITY. NO ADDITIONAL COMPENSATION WILL BE MADE TO THE CONTRACTOR FOR LOWERING THE WATER LINE TO AVOID CONFLICTS WITH EXISTING UTILITIES.

EXISTING DITCHES: WHERE IT BECOMES NECESSARY TO LOCATE A MAIN LINE VALVE, FIRE HYDRANT OR MANHOLE IN AN EXISTING DITCH, THE CONTRACTOR SHALL RELOCATE THE DITCH BEHIND THE PROPOSED VALVE, HYDRANT OR MANHOLE.

MANHOLE TOPS: WHERE MANHOLES ARE LOCATED WITHIN PUBLIC OR PRIVATE PAVEMENT, SIDEWALK, CONCRETE PAD OR PAVED SHOULDER, THE TOPS SHALL BE BUILT TO EXISTING PAVEMENT ELEVATIONS. ELSEWHERE MANHOLES SHALL BE BUILT OR SUBSEQUENTLY ADJUSTED TO PROVIDE POSITIVE DRAINAGE AWAY FROM THE MANHOLE. THE COST OF ADJUSTMENT IS TO BE INCLUDED IN THE PRICE BID FOR THE MANHOLE.

FINAL GRADING & CLEAN-UP: THE CONTRACTOR SHALL CLEAN UP ALL DEBRIS & MATERIALS RESULTING FROM HIS OPERATION & RESTORE ALL SURFACES, STRUCTURES, DITCHES, SIGNS, MAILBOXES, FENCES, GUARDRAILS, OR OTHER PHYSICAL FEATURES OR PROPERTY DISTURBED OR DAMAGED DURING WORK UNDER THIS CONTRACT TO THEIR ORIGINAL CONDITION TO THE SATISFACTION OF THE ENGINEER. THE COST OF ALL SUCH WORK SHALL BE INCLUDED WITH THE VARIOUS RELATED ITEMS.

SEEDING & MULCHING: ALL AREAS DISTURBED DURING CONSTRUCTION SHALL BE RESTORED TO THEIR ORIGINAL CONDITION & ELEVATION OR TO THE PROPOSED ELEVATIONS SHOWN ON THE DRAWINGS, & PROPER DRAINAGE SHALL BE PROVIDED. AFTER FINAL GRADING, THE SEED BED SHALL BE RAKED & ALL STONES, CLODS, LUMPS & OTHER FOREIGN MATERIAL GREATER THAN 1" IN DIAMETER SHALL BE REMOVED PRIOR TO SEEDING & MULCHING. ALL AREAS SHALL BE SEEDED PER ITEM 659.09, CLASS 1 FOR RESIDENTIAL AREAS OR CLASS 2 FOR RURAL ROADSIDE AREAS, UNLESS OTHERWISE SPECIFIED. THE CONTRACTOR SHALL WATER, RE-SEED & MULCH AS NECESSARY UNTIL AN ACCEPTABLE STAND OF GRASS IS ACHIEVED.

WATER LINE CONSTRUCTION: ALL PIPE, FITTINGS & METHODS OF CONSTRUCTION & WORKMANSHIP FOR WATER LINES & APPURTENANCES SHOWN ON THESE PLANS SHALL CONFORM TO THE REQUIREMENTS OF HOCKING COUNTY, IN FORCE ON THE DATE OF CONTRACT, UNLESS SUCH REQUIREMENTS ARE UPGRADED BY THE FOLLOWING SPECIFICATIONS OR BY THE CONSTRUCTION DETAILS SET FORTH HEREIN.

MATERIAL: ALL PIPE, FITTINGS, VALVES & METHODS OF CONSTRUCTION SHALL BE SUPPLIED WITH MATERIAL CONFORMING TO THE LATEST SPECIFICATIONS FOR THE FOLLOWING:

(1) DUCTILE IRON, CLASS 53 FOR SIZES 3" TO 10" & CLASS 54 FOR SIZES 12" & ABOVE, MANUFACTURED IN ACCORDANCE WITH AWWA C151, HAVING A BITUMINOUS COATED CEMENT LINING COMPLYING WITH AWWA C104 & AN OUTSIDE COATING OF BITUMASTIC ENAMEL OR APPROVED EQUIVALENT. ALL JOINTS SHALL CONFORM TO AWWA C111.

(2) POLYVINYL CHLORIDE PIPE, AWWA C905 DR18 FOR SIZES 14" & ABOVE, AWWA C900 DR18 FOR SIZES 4" TO 12".

(3) WATER LINE PIPE & FITTINGS SHALL BE AWWA C153, CEMENT LINED PER AWWA C104.

(4) VALVES SHALL HAVE A NON-RISING STEM, LEFT-HAND OPEN (COUNTER-CLOCKWISE) WITH DOUBLE O-RING STEM SEALS. VALVES SHALL HAVE END JOINTS CONFORMING TO AWWA C111. VALVES SHALL PASS A SEAT TEST AT 200 PSI WITHOUT LEAKAGE. THE VALVE SHELL SHALL PASS A SHELL TEST WITH THE VALVE IN THE OPEN POSITION AT 400 PSI WITHOUT LEAKAGE THROUGH METAL, FLANGED JOINTS OR STEM SEALS. ADDITIONALLY, THE VALVES SHALL CONFORM TO THE FOLLOWING:

AWWA C515 HAVING A SEALING MECHANISM THAT PROVIDES ZERO LEAKAGE AT THE WATER WORKING PRESSURE AGAINST LINE FLOW FROM EITHER DIRECTION. NO EXPOSED METAL SEAMS, EDGES, SCREWS, ETC. SHALL BE WITHIN THE WATERWAY IN THE CLOSED POSITION (ALL SURFACES SHALL BE RUBBER COVERED). THE RUBBER COVERED GATE SHALL NOT BE WEDGED IN A POCKET NOR SLIDE ACROSS THE SEATING SURFACE TO OBTAIN TIGHT CLOSURE. ALL INTERNAL & EXTERNAL FERROUS SURFACES, INCLUDING THE INTERIOR OF THE GATE, BOLT HOLES & FLANGE FACES, SHALL BE COATED, PRIOR TO ASSEMBLY OF THE VALVE, WITH EPOXY HAVING A MINIMUM THICKNESS OF 8 MILS. THERE SHALL BE AN O-RING SEAL ABOVE THE STORM COLLAR & AN O-RING SEAL BELOW THE STEM COLLAR WITH THE AREA BETWEEN THE O-RING SEALS FILLED WITH LUBRICANT. THERE SHALL BE ANTI-FRICTION WASHERS AT THE STEM COLLAR.

(5) SERVICE LINES SHALL BE:

- (A) COPPER PIPE, TYPE K
- (B) DRISCOPIPE 5100, ULTRA-LINE, ULTRA HIGH MOLECULAR WEIGHT POLYETHYLENE, AWWA C901, COPPER TUBE SIZE OD ASTM D-2737 SDR 9 (PE3408)
- (C) WATER LINE PIPE MATERIAL

(6) CORPORATION STOPS SHALL BE EQUIVALENT TO MUELLER H-1 5000.

(7) CURB STOPS SHALL BE EQUIVALENT TO MUELLER H-15200 WITH A BOX EQUIVALENT TO MUELLER H-1 0350, SIZE 94E.

(8) TAPPING SLEEVES SHALL BE A MECHANICAL JOINT SLEEVE & SHALL PROVIDE FULL SUPPORT AROUND THE CIRCUMFERENCE OF THE PIPE, WITH SUFFICIENT WIDTH & BEARING TO NOT DISTORT THE PIPE WHEN TIGHTENED. LUGS OR RIDGES WHICH MAY SCRAPE OR CUT INTO PIPE ARE NOT ACCEPTABLE.

(9) TAPPING SADDLES SHALL BE EQUIVALENT TO FORD STYLE FS 101 FOR 3/4" & 1" SERVICES, & FORD STYLE FS202 FOR 1-1/4" THROUGH 2-1/2" SERVICES.

(10) ALL JOINTS, FITTING, VALVES & APPURTENANCES SHALL BE FURNISHED WITH ALL ACCESSORIES.

CONNECTING WATER LINES: THE CONNECTION OF EXISTING WATER LINES & SERVICES TO PROPOSED WATER LINES SHALL BE DONE IN A MANNER THAT WILL CAUSE MINIMUM INCONVENIENCE TO THOSE WITH AFFECTED SERVICE. WORK CONCERNING THE DISCONNECTION & RECONNECTION OF EXISTING WATER LINES SHALL BE DONE BETWEEN THE HOURS OF 10:00 P.M. & 5:00 A.M. OR AS DIRECTED BY THE ENGINEER. NO SUCH WORK SHALL BEGIN UNTIL THE ENGINEER, THE LOCAL FIRE DEPARTMENT & THE AFFECTED CUSTOMERS ARE NOTIFIED OF THE EXTENT, NATURE & TIME OF THE ANTICIPATED WORK, & THE METHOD & SCHEDULE OF SUCH WORK HAS BEEN APPROVED BY THE LOCAL WATER COMPANY.

TAPS: A TAP PERMIT FOR EACH WATER SERVICE MUST BE OBTAINED FROM THE APPROPRIATE ENTITIES PRIOR TO CONNECTING ANY CUSTOMERS TO THE WATER LINE.

DEAD END LINES: ON DEAD END LINES, 2 ~ 3/4" TAPS SHALL BE INSTALLED WITHIN 2' OF THE END OF THE MAIN.

PLUG POLES: A 2" X 2" HARDWOOD POLE SHALL BE PLACED AT ALL END-OF-LINE STUBS AT THE THRUST BLOCK. EACH POLE SHALL HAVE A 1" MINIMUM LENGTH OF RE-BAR ATTACHED TO ITS TOP END. THE TOP OF THE POLE SHALL BE BURIED APPROXIMATELY 3" BELOW THE FINISHED GRADE.

MINIMUM DEPTH: WATER LINES SHALL BE LAID WITH A MINIMUM OF 4' FROM TOP OF PROPOSED OR FINISHED GRADE (OR TOP OF CURB) TO THE TOP OF THE WATER LINE.

LINE CROSSINGS: AT ALL POINTS OF CROSSING BETWEEN WATER MAINS & SEWERS, THE BACKFILL SHALL BE GRANULAR MATERIAL BETWEEN THE DEEPER & SHALLOWER PIPE, AS DIRECTED BY THE ENGINEER.

BACKFILLING WATER LINE TRENCHES: TRENCHES UNDER EXISTING OR PROPOSED PAVED AREAS OR DRIVES SHALL BE BACKFILLED WITH COMPACTED GRANULAR MATERIAL FROM THE BOTTOM OF THE TRENCH TO THE PAVEMENT SUB-GRADE OR TO A PLANE 6" BELOW THE TOP OF THE GROUND. BETWEEN THE LIMITS OF 5' BEYOND THE EDGE OF PAVEMENT, PAVED SHOULDER OR BACK OF CURB, TRENCHES OUTSIDE PAVEMENT LIMITS SHALL BE BACKFILLED WITH SUITABLE MATERIAL AS DEFINED IN THE INSTALLATION DETAILS.

DISINFECTION: ALL WATER MAINS SHALL BE DISINFECTED BY THE CONTRACTOR IN ACCORDANCE WITH THE REQUIREMENTS OF THE LOCAL WATER COMPANY & THE APPLICABLE SECTIONS OF AWWA C651 (WATER MAINS), C652 (STORAGE FACILITIES), C653 (WATER PLANTS), & C654 (WELLS). ALL LABOR, MATERIAL & EQUIPMENT INCLUDING DISINFECTION TAPS & BLOW-OFF TAPS WILL BE FURNISHED & PAID FOR BY THE CONTRACTOR, INCLUDING TAPPING VALVES, SUFFICIENT TUBING OR PIPE TO EXTEND OUTSIDE THE TRENCH & AN OPERABLE VALVE ABOVE GROUND. BLOW-OFFS SHALL BE INSTALLED WHERE SHOWN ON THE CONSTRUCTION DRAWINGS OR AS DIRECTED IN THE FIELD. THE TIME & SECTION OF LINE (OR FACILITY) TO BE DISINFECTED SHALL BE APPROVED BY THE ENGINEER. SPECIAL ATTENTION IS DIRECTED TO APPLICABLE SECTIONS OF AWWA C651, PARTICULARLY FOR FLUSHING & FOR DISINFECTING VALVES & FIRE HYDRANTS. ALL LABORATORY TESTS ASSOCIATED WITH VERIFYING PROPER DISINFECTION SHALL BE PAID FOR BY THE CONTRACTOR.

PRESSURE TESTING: A HYDROSTATIC TEST AS REQUIRED IN APPLICABLE SECTIONS OF AWWA C600 SHALL BE APPLIED TO THE WATER MAIN. IF THERE ARE INDICATIONS OF LEAKS UNDER THIS PRESSURE TEST, THE CONTRACTOR SHALL LOCATE & REPAIR THEM AT HIS COST UNTIL THE LEAKAGE IS WITHIN THE SPECIFIED ALLOWANCE. ALL BENDS, JOINT DEFLECTIONS & HYDRANTS SHALL HAVE APPROPRIATE THRUST BLOCKING.

WORKING PRESSURE: THIS PROJECT HAS BEEN DESIGNED SO THAT NORMAL WORKING PRESSURE WILL NOT BE LESS THAN 35 PSI. INDIVIDUAL BOOSTER PUMPS ARE PROHIBITED.

VALVE EXTENSIONS: IF THE TOP OF THE OPERATING NUT IS MORE THAN 36" BELOW FINISHED GRADE, AN EXTENSION STEM SHALL BE FURNISHED TO BRING THE TOP OF THE OPERATING NUT TO WITHIN 24" OF FINISHED GRADE.



**Know what's below.
Call before you dig.**

DAVIS-BACON WAGE DETERMINATIONS

SECTION E

"General Decision Number: OH20240001 09/06/2024

Superseded General Decision Number: OH20230001

State: Ohio

Construction Types: Heavy and Highway

Counties: Ohio Statewide.

Heavy and Highway Construction Projects

Note: Contracts subject to the Davis-Bacon Act are generally required to pay at least the applicable minimum wage rate required under Executive Order 14026 or Executive Order 13658. Please note that these Executive Orders apply to covered contracts entered into by the federal government that are subject to the Davis-Bacon Act itself, but do not apply to contracts subject only to the Davis-Bacon Related Acts, including those set forth at 29 CFR 5.1(a)(1).

If the contract is entered into on or after January 30, 2022, or the contract is renewed or extended (e.g., an option is exercised) on or after January 30, 2022:	Executive Order 14026 generally applies to the contract. The contractor must pay all covered workers at least \$17.20 per hour (or the applicable wage rate listed on this wage determination, if it is higher) for all hours spent performing on the contract in 2024.
---	---

If the contract was awarded on or between January 1, 2015 and January 29, 2022, and the contract is not renewed or extended on or after January 30, 2022:	Executive Order 13658 generally applies to the contract. The contractor must pay all covered workers at least \$12.90 per hour (or the applicable wage rate listed on this wage determination, if it is higher) for all hours spent performing on that contract in 2024.
---	--

The applicable Executive Order minimum wage rate will be adjusted annually. If this contract is covered by one of the Executive Orders and a classification considered necessary for performance of work on the contract does not appear on this wage determination, the contractor must still submit a

conformance request.

Additional information on contractor requirements and worker protections under the Executive Orders is available at <http://www.dol.gov/whd/govcontracts>.

Modification Number	Publication Date
0	01/05/2024
1	01/26/2024
2	03/08/2024
3	04/05/2024
4	07/05/2024
5	07/26/2024
6	08/23/2024
7	09/06/2024
8	09/06/2024

BROH0001-001 06/01/2023

DEFIANCE, FULTON (Excluding Fulton, Amboy & Swan Creek Townships), HENRY (Excluding Monroe, Bartlow, Liberty, Washington, Richfield, Marion, Damascus & Townships & that part of Harrison Township outside corporate limits of city of Napoleon), PAULDING, PUTNAM and WILLIAMS COUNTIES

	Rates	Fringes
Bricklayer, Stonemason.....	\$ 32.40	19.30

BROH0001-004 06/01/2023

	Rates	Fringes
CEMENT MASON/CONCRETE FINISHER...	\$ 32.40	19.30

BROH0003-002 06/01/2023

FULTON (Townships of Amboy, Swan Creek & Fulton), HENRY (Townships of Washington, Damascus, Richfield, Bartlow, Liberty, Harrison, Monroe, & Marion), LUCAS and WOOD (Townships of Perrysburg, Ross, Lake, Troy, Freedom, Montgomery, Webster, Center, Portage, Middleton, Plain, Liberty, Henry, Washington, Weston, Milton, Jackson & Grand Rapids) COUNTIES

	Rates	Fringes
Bricklayer, Stonemason.....	\$ 32.40	19.30

BROH0005-003 06/01/2020

CUYAHOGA, LORAIN & MEDINA (Hinckley, Granger, Brunswick,

Liverpool, Montville, York, Homer, Harrisville, Chatham,
Litchfield & Spencer Townships and the city of Medina)

Rates Fringes

BRICKLAYER

BRICKLAYERS; CAULKERS; CLEANERS; POINTERS; & STONEMASONS.....	\$ 36.64	17.13
SANDBLASTERS.....	\$ 36.39	17.13
SEWER BRICKLAYERS & STACK BUILDERS.....	\$ 36.64	17.13
SWING SCAFFOLDS.....	\$ 37.14	17.13

BROH0006-005 06/01/2023

CARROLL, COLUMBIANA (Knox, Butler, West & Hanover Townships),
STARK & TUSCARAWAS

Rates Fringes

Bricklayer, Stonemason.....	\$ 32.40	19.30
-----------------------------	----------	-------

BROH0007-002 06/01/2023

LAWRENCE

Rates Fringes

Bricklayer, Stonemason.....	\$ 32.40	19.30
-----------------------------	----------	-------

BROH0007-005 06/01/2023

PORTAGE & SUMMIT

Rates Fringes

BRICKLAYER.....	\$ 32.40	19.30
-----------------	----------	-------

BROH0007-010 06/01/2023

PORTAGE & SUMMIT

Rates Fringes

MASON - STONE.....	\$ 32.40	19.30
--------------------	----------	-------

BROH0008-001 06/01/2023

COLUMBIANA (Salem, Perry, Fairfield, Center, Elk Run,
Middleton, & Unity Townships and the city of New Waterford),
MAHONING & TRUMBULL

Rates Fringes

BRICKLAYER.....\$ 32.40 19.30

BROH0009-002 06/01/2023

BELMONT & MONROE COUNTIES and the Townships of Warren & Mt. Pleasant and the Village of Dillonvale in JEFFERSON COUNTY

Rates Fringes

Bricklayer, Stonemason.....\$ 32.40 19.30

Refractory.....\$ 31.45 19.01

BROH0010-002 06/01/2023

COLUMBIANA (St. Clair, Madison, Wayne, Franklin, Washington, Yellow Creek & Liverpool Townships) & JEFFERSON (Brush Creek & Saline Townships)

Rates Fringes

Bricklayer, Stonemason.....\$ 32.40 19.30

BROH0014-002 06/01/2023

HARRISON & JEFFERSON (Except Mt. Pleasant, Warren, Brush Creek, Saline & Salineville Townships & the Village of Dillonvale)

Rates Fringes

Bricklayer, Stonemason.....\$ 32.40 19.30

BROH0016-002 06/01/2023

ASHTABULA, GEAUGA, and LAKE COUNTIES

Rates Fringes

Bricklayer, Stonemason.....\$ 32.40 19.30

BROH0018-002 06/01/2023

BROWN, BUTLER, CLERMONT, HAMILTON, PREBLE (Gasper, Dixon, Israel, Lanier, Somers & Gratis Townships) & WARREN COUNTIES:

Rates Fringes

Bricklayer, Stonemason.....\$ 32.40 19.30

BROH0022-004 06/01/2023

CHAMPAIGN, CLARK, CLINTON, DARKE, GREENE, HIGHLAND, LOGAN,
MIAMI, MONTGOMERY, PREBLE (Jackson, Monroe, Harrison, Twin,
Jefferson & Washington Townships) and SHELBY COUNTIES

Rates Fringes

Bricklayer, Stonemason.....\$ 32.40 19.30

BROH0032-001 06/01/2023

GALLIA & MEIGS

Rates Fringes

Bricklayer, Stonemason.....\$ 32.40 19.30

BROH0035-002 06/01/2023

ALLEN, AUGLAIZE, MERCER and VAN WERT COUNTIES

Rates Fringes

Bricklayer, Stonemason.....\$ 32.40 19.30

BROH0039-002 06/01/2023

ADAMS & SCIOTO

Rates Fringes

Bricklayer, Stonemason.....\$ 32.40 19.30

BROH0040-003 06/01/2023

ASHLAND, CRAWFORD, HARDIN, HOLMES, MARION, MORROW, RICHLAND,
WAYNE and WYANDOT (Except Crawford, Ridge, Richland & Tymochtee
Townships) COUNTIES

Rates Fringes

Bricklayer, Stonemason.....\$ 32.40 19.30

FOOTNOTE: Layout Man and Sawman rate: \$1.00 per hour above
journeyman rate.

Free standing stack work ground level to top of stack;
Sandblasting and laying of carbon masonry material in swing
stage and/or scaffold; Ramming and spading of plastics and
gunniting: \$1.50 per hour above journeyman rate.

""Hot"" work: \$2.50 above journeyman rate.

BROH0044-002 06/01/2023

Rates Fringes

Bricklayer, Stonemason
COSHOCTON, FAIRFIELD,
GUERNSEY, HOCKING, KNOX,
KICKING, MORGAN,
MUSKINGUM, NOBLE (Beaver,
Buffalo, Seneca & Wayne
Townships) & PERRY
COUNTIES:.....\$ 32.40 19.30

BROH0045-002 06/01/2023

FAYETTE, JACKSON, PIKE, ROSS and VINTON COUNTIES

Rates Fringes

Bricklayer, Stonemason.....\$ 35.39 17.47

BROH0046-002 06/01/2023

ERIE, HANCOCK, HURON, OTTAWA, SANDUSKY, SENECA, WOOD (Perry &
Bloom Townships) and WYANDOT (Tymochtee, Crawford, Ridge &
Richland Townships) COUNTIES & the Islands of Lake Erie north
of Sandusky

Rates Fringes

Bricklayer, Stonemason.....\$ 32.40 19.30

FOOTNOTE: Layout Man and Sawman rate: \$1.00 per hour above
journeyman rate.

Free standing stack work ground level to top of stack;
Sandblasting and laying of carbon masonry material in swing
stage and/or scaffold; Ramming and spading of plastics and
gunniting: \$1.50 per hour above journeyman rate.

""Hot"" work: \$2.50 above journeyman rate.

BROH0052-001 06/01/2023

ATHENS COUNTY

Rates Fringes

Bricklayer, Stonemason.....\$ 32.40 19.30

BROH0052-003 06/01/2023

NOBLE (Brookfield, Noble, Center, Sharon, Olive, Enoch, Stock,
Jackson, Jefferson & Elk Townships) and WASHINGTON COUNTIES

Rates	Fringes
Bricklayer, Stonemason.....\$ 32.40	19.30

BROH0055-003 06/01/2023	

DELAWARE, FRANKLIN, MADISON, PICKAWAY and UNION COUNTIES

Rates	Fringes
Bricklayer, Stonemason.....\$ 32.40	19.30

CARP0003-004 05/01/2017	

MAHONING & TRUMBULL

Rates	Fringes
CARPENTER.....\$ 26.20	17.42

CARP0069-003 05/01/2017	

CARROLL, STARK, TUSCARAWAS & WAYNE

Rates	Fringes
CARPENTER.....\$ 25.98	15.98

CARP0069-006 05/01/2017	

COSHOCTON, HOLMES, KNOX & MORROW

Rates	Fringes
CARPENTER.....\$ 24.04	15.29

CARP0171-002 05/01/2024	

BELMONT, COLUMBIANA, HARRISON, JEFFERSON & MONROE

Rates	Fringes
CARPENTER.....\$ 31.82	25.11

CARP0200-002 05/01/2024	

ADAMS, ATHENS, DELAWARE, FAIRFIELD, FAYETTE, FRANKLIN, GALLIA,
GUERNSEY, HIGHLAND, HOCKING, JACKSON, LAWRENCE, LICKING,
MADISON, MARION, MEIGS, MORGAN, MUSKINGUM, NOBLE, PERRY,

PICKAWAY, PIKE, ROSS, SCIOTO, UNION, VINTON and WASHINGTON
COUNTIES

	Rates	Fringes
CARPENTER.....	\$ 33.15	22.43
Diver.....	\$ 39.41	10.40
PILEDRIVERMAN.....	\$ 33.15	22.43

CARP0248-005 07/01/2008

LUCAS & WOOD

	Rates	Fringes
CARPENTER.....	\$ 27.27	14.58

CARP0248-008 07/01/2008

	Rates	Fringes
CARPENTER DEFIANCE, FULTON, HANCOCK, HENRY, PAULDING & WILLIAMS COUNTIES.....	\$ 23.71	13.28

CARP0254-002 05/01/2017

ASHTABULA, CUYAHOGA, GEAUGA & LAKE

	Rates	Fringes
CARPENTER.....	\$ 32.40	16.97

CARP0372-002 05/01/2024

ALLEN, AUGLAIZE, HARDIN, MERCER, PUTNAM & VAN WERT

	Rates	Fringes
CARPENTER.....	\$ 30.73	25.09

CARP0639-003 05/01/2017

MEDINA, PORTAGE & SUMMIT

	Rates	Fringes
CARPENTER.....	\$ 30.42	16.99

CARP0735-002 05/01/2024

ASHLAND, ERIE, HURON, LORAIN & RICHLAND

Rates Fringes

CARPENTER.....\$ 33.43 22.31

CARP1311-001 05/01/2017

BROWN, BUTLER, CHAMPAIGN, CLARK, CLERMONT, CLINTON, DARKE,
GREENE, HAMILTON, LOGAN, MIAMI, MONTGOMERY, PREBLE, SHELBY &
WARREN

Rates Fringes

Carpenter & Piledrivermen.....\$ 29.34 15.95

Diver.....\$ 40.58 9.69

CARP1393-002 05/01/2024

CRAWFORD, DEFIANCE, FULTON, HANCOCK, HENRY, LUCAS, OTTAWA,
PAULDING, SANDUSKY, SENECA, WILLIAMS & WOOD

Rates Fringes

Piledrivermen & Diver's Tender...\$ 36.84 27.72

DIVERS - \$250.00 per day

CARP1393-003 05/01/2024

ALLEN, AUGLAIZE, HARDIN, MERCER, PUTNAM, VAN WERT & WYANDOT

Rates Fringes

Piledrivermen & Diver's Tender...\$ 34.68 27.60

DIVERS - \$250.00 per day

CARP1871-006 05/01/2017

BELMONT, HARRISON, & MONROE

Rates Fringes

Diver, Wet.....\$ 48.11 17.33

Piledrivermen; Diver, Dry.....\$ 32.07 17.33

CARP1871-008 05/01/2017

ASHLAND, ASHTABULA, CUYAHOGA, ERIE, GEAUGA, HURON, LAKE,
LORAIN, MEDINA, PORTAGE, RICHLAND & SUMMIT

Rates Fringes

Diver, Wet.....\$ 45.80 18.84
Piledrivermen; Diver, Dry.....\$ 30.53 18.84

CARP1871-014 05/01/2017

CARROLL, STARK, TUSCARAWAS & WAYNE

Rates Fringes

Diver, Wet.....\$ 38.34 16.95
Piledrivermen; Diver, Dry.....\$ 25.56 16.95

CARP1871-015 05/01/2017

COSHOCTON, HOLMES, KNOX & MORROW

Rates Fringes

Diver, Wet.....\$ 37.34 16.07
Piledrivermen; Diver, Dry.....\$ 24.89 16.07

CARP1871-017 05/01/2017

MAHONING & TRUMBULL

Rates Fringes

Diver, Wet.....\$ 40.65 17.62
Piledrivermen; Diver, Dry.....\$ 27.10 17.62

CARP2235-012 01/01/2014

COLUMBIANA & JEFFERSON

Rates Fringes

PILEDRIVERMAN.....\$ 31.74 16.41

CARP2239-001 07/01/2008

CRAWFORD, OTTAWA, SANDUSKY, SENECA & WYANDOT

Rates Fringes

CARPENTER.....\$ 23.71 13.28

ELEC0008-002 05/29/2023

DEFIANCE, FULTON, HANCOCK, HENRY, LUCAS, OTTAWA, PAULDING,
PUTNAM, SANDUSKY, SENECA, WILLIAMS & WOOD

	Rates	Fringes
CABLE SPLICER.....	\$ 38.98	18.96
ELECTRICIAN.....	\$ 46.38	4.5%+21.96

 ELEC0032-003 06/01/2024

ALLEN, AUGLAIZE, HARDIN, LOGAN, MERCER, SHELBY, VAN WERT &
 WYANDOT (Crawford, Jackson, Marseilles, Mifflin, Ridgeland,
 Ridge & Salem Townships)

	Rates	Fringes
ELECTRICIAN.....	\$ 35.17	22.92

 ELEC0038-002 04/29/2024

CUYAHOGA, GEAUGA (Bainbridge, Chester & Russell Townships) &
 LORAIN (Columbia Township)

	Rates	Fringes
ELECTRICIAN Excluding Sound & Communications Work.....	\$ 45.23	23.88

FOOTNOTES;
 a. 6 Paid Holidays: New Year's Day; Memorial Day; July 4th;
 Labor Day; Thanksgiving Day; & Christmas Day
 b. 1 week's paid vacation for 1 year's service; 2 weeks' paid
 vacation for 2 or more years' service

 ELEC0038-008 04/24/2023

CUYAHOGA, GEAUGA (Bainbridge, Chester & Russell Townships) &
 LORAIN (Columbia Township)

	Rates	Fringes
Sound & Communication Technician Communications Technician...	\$ 29.80	13.80
Installer Technician.....	\$ 28.55	13.76

FOOTNOTES;
 a. 6 Paid Holidays: New Year's Day; Memorial Day; July 4th;
 Labor Day; Thanksgiving Day; & Christmas Day
 b. 1 week's paid vacation for 1 year's service; 2 weeks' paid
 vacation for 2 or more years' service

ELEC0064-003 11/27/2023

COLUMBIANA (Butler, Fairfield, Perry, Salem & Unity Townships)
MAHONING (Austintown, Beaver, Berlin, Boardman, Canfield,
Ellsworth, Coitsville, Goshen, Green, Jackson, Poland,
Springfield & Youngstown Townships), & TRUMBULL (Hubbard &
Liberty Townships)

	Rates	Fringes
ELECTRICIAN.....	\$ 37.90	20.08

ELEC0071-001 01/01/2024

ASHLAND, CHAMPAIGN, CLARK, COSHOCTON, CRAWFORD, DELAWARE,
FAIRFIELD, FAYETTE, FRANKLIN, GUERNSEY, HIGHLAND, HOCKING,
JACKSON (Coal, Jackson, Liberty, Milton, Washington & Wellston
Townships), KNOX, LICKING, MADISON, MARION, MONROE, MORGAN,
MORROW, MUSKINGUM, NOBLE, PERRY, PICKAWAY, PIKE (Beaver,
Benton, Jackson, Mifflin, Pebble, Peepee, Perry & Seal
Townships), RICHLAND, ROSS, TUSCARAWAS (Auburn, Bucks, Clay,
Jefferson, Oxford, Perry, Salem, Rush, Washington & York
Townships), UNION, VINTON (Clinton, Eagle, Elk, Harrison,
Jackson, Richland & Swan Townships), and WASHINGTON COUNTIES

	Rates	Fringes
Line Construction		
Equipment Operators.....	\$ 39.11	17.14
Groundmen.....	\$ 25.90	13.97
Linemen & Cable Splicers....	\$ 44.52	18.43

ELEC0071-004 01/01/2024

AUGLAIZE, CLINTON, DARKE, GREENE, LOGAN, MERCER, MIAMI,
MONTGOMERY, PREBLE, and SHELBY COUNTIES

	Rates	Fringes
Line Construction		
Equipment Operator.....	\$ 39.11	17.14
Groundman.....	\$ 25.90	13.97
Lineman & Cable Splicers....	\$ 44.52	18.43

ELEC0071-005 01/01/2024

ASHTABULA, CUYAHOGA, GEAUGA, LAKE & LORAIN

Rates Fringes

LINE CONSTRUCTION: Equipment

Operator

DOT/Traffic Signal & Highway Lighting Projects...	\$ 37.43	26%+7.75
Municipal Power/Transit Projects.....	\$ 47.86	27%+7.65

LINE CONSTRUCTION: Groundman

DOT/Traffic Signal & Highway Lighting Projects...	\$ 25.63	26%+7.75
Municipal Power/Transit Projects.....	\$ 31.91	27%+7.65

LINE CONSTRUCTION:

Linemen/Cable Splicer

DOT/Traffic Signal & Highway Lighting Projects...	\$ 42.20	26%+7.75
Municipal Power/Transit Projects.....	\$ 53.18	27%+7.65

ELEC0071-008 01/01/2024

COLUMBIANA, MAHONING, and TRUMBULL COUNTIES

Rates Fringes

Line Construction

Equipment Operator.....	\$ 39.11	17.14
Groundman.....	\$ 25.90	13.97
Lineman & Cable Splicers....	\$ 44.52	18.43

ELEC0071-010 01/01/2024

Rates Fringes

Line Construction

Equipment Operator.....	\$ 39.11	17.14
Groundman.....	\$ 25.90	13.97
Lineman & Cable Splicers....	\$ 44.52	18.43

ELEC0071-013 01/01/2024

BROWN, BUTLER, CLERMONT, HAMILTON, and WARREN COUNTIES

Rates Fringes

Line Construction

Equipment Operator.....	\$ 39.11	17.14
Groundman.....	\$ 25.90	13.97
Lineman & Cable Splicers....	\$ 44.52	18.43

ELEC0071-014 01/01/2024

ADAMS, ATHENS, GALLIA, JACKSON (Bloomfield, Franklin, Hamilton, Lick, Jefferson, Scioto & Madison Townships), LAWRENCE, MEIGS, PIKE (Camp Creek, Marion, Newton, Scioto, Sunfish & Union

Townships), SCIOTO & VINTON (Brown, Knox, Madison, Vinton & Wilkesville Townships)

Rates Fringes

Line Construction

Equipment Operator.....	\$ 39.11	17.14
Groundman.....	\$ 25.90	13.97
Lineman & Cable Splicers....	\$ 44.52	18.43

ELEC0082-002 12/04/2023

CLINTON, DARKE, GREENE, MIAMI, MONTGOMERY, PREBLE & WARREN
(Wayne, Clear Creek & Franklin Townships)

Rates Fringes

ELECTRICIAN.....	\$ 36.00	21.99
------------------	----------	-------

* ELEC0082-006 11/28/2022

CLINTON, DARKE, GREENE, MIAMI, MONTGOMERY, PREBLE & WARREN
(Wayne, Clear Creek & Franklin Townships)

Rates Fringes

Sound & Communication

Technician

Cable Puller.....	\$ 13.10 **	4.76
Installer/Technician.....	\$ 26.20	13.89

ELEC0129-003 02/26/2024

LORAIN (Except Columbia Township) & MEDINA (Litchfield & Liverpool Townships)

Rates Fringes

ELECTRICIAN.....	\$ 41.40	18.36
------------------	----------	-------

ELEC0129-004 02/26/2024

ERIE & HURON (Lyme, Ridgefield, Norwalk, Townsend, Wakeman, Sherman, Peru, Bronson, Hartland, Clarksfield, Norwich, Greenfield, Fairfield, Fitchville & New London Townships)

Rates Fringes

ELECTRICIAN.....	\$ 41.40	18.36
------------------	----------	-------

ELEC0141-003 06/02/2024

BELMONT COUNTY

Rates Fringes

CABLE SPLICER.....\$ 42.94 27.74
ELECTRICIAN.....\$ 39.04 27.62

ELEC0212-003 11/26/2018

BROWN, CLERMONT & HAMILTON

Rates Fringes

Sound & Communication
Technician.....\$ 24.35 10.99

ELEC0212-005 06/03/2024

BROWN, CLERMONT, and HAMILTON COUNTIES

Rates Fringes

ELECTRICIAN.....\$ 35.43 22.05

ELEC0245-001 08/29/2022

ALLEN, HARDIN, VAN WERT & WYANDOT (Crawford, Jackson, Marseilles, Mifflin, Richland, Ridge & Salem Townships)

Rates Fringes

Line Construction

Equipment Operator.....\$ 32.37 26.5%+7.25
Groundman Truck Driver.....\$ 19.35 7.00+27.25%
Lineman.....\$ 44.22 7.00+27.25%

FOOTNOTE: a. Half day's Paid Holiday: The last 4 hours of the workday prior to Christmas or New Year's Day

ELEC0245-003 01/01/2024

DEFIANCE, FULTON, HANCOCK, HENRY, HURON, LUCAS, OTTAWA, PAULDING, PUTNAM, SANDUSKY, SENECA, WILLIAMS, and WOOD COUNTIES

Rates Fringes

Line Construction

Cable Splicer.....\$ 52.53 7.75+27%

Groundman/Truck Driver.....	\$ 19.99	7.75+27%
Heli-arc Welding.....	\$ 45.98	7.75+27%
Lineman.....	\$ 45.68	7.75+27%
Operator - Class 1.....	\$ 36.54	7.75+27%
Operator - Class 2.....	\$ 31.98	7.75+27%
Traffic Signal & Lighting Technician.....	\$ 41.11	7.75+27%

FOOTNOTE: a. 6 Observed Holidays: New Year's Day; Memorial Day; Independence Day; Labor Day; Thanksgiving Day; & Christmas Day. Employees who work on a holiday shall be paid at a rate of double their applicable classified straight-time rates for the work performed on such holiday.

ELEC0245-004 08/28/2023

ERIE COUNTY

Rates Fringes

Line Construction

Cable Splicer.....	\$ 49.14	26.75%+6.75
Cablesplicer.....	\$ 52.76	27%+7.50
Groundman/Truck Driver.....	\$ 20.07	27%+7.50
Lineman.....	\$ 45.88	27%+7.50
Operator - Class 1.....	\$ 36.70	27%+7.50
Operator - Class 2.....	\$ 32.12	27%+7.50

FOOTNOTE: a. 6 Observed Holidays: New Year's Day; Memorial Day; Independence Day; Labor Day; Thanksgiving Day; & Christmas Day. Employees who work on a holiday shall be paid at a rate of double their applicable classified straight-time rates for the work performed on such holiday.

ELEC0246-001 10/30/2023

Rates Fringes

ELECTRICIAN.....	\$ 42.50	55%+13.88
------------------	----------	-----------

FOOTNOTE: a. 1 1/2 Paid Holidays: The last scheduled workday prior to Christmas & 4 hours on Good Friday.

ELEC0306-005 05/27/2024

MEDINA (Brunswick, Chatham, Granger, Guilford, Harrisville, Hinckley, Homer, Lafayette, Medina, Montville, Sharon, Spencer, Wadsworth, Westfield & York Townships), PORTAGE (Atwater, Aurora, Brimfield, Deerfield, Franklin, Mantua, Randolph, Ravenna, Rootstown, Shalersville, Streetsboro & Suffield Townships), SUMMIT & WAYNE (Baughman, Canaan, Chester,

Chippewa, Congress, Green, Milton, & Wayne Townships)

Rates Fringes

CABLE SPLICER.....\$ 36.87 16.56
ELECTRICIAN.....\$ 42.55 5.25%+20.95

ELEC0317-002 05/29/2023

GALLIA & LAWRENCE

Rates Fringes

CABLE SPLICER.....\$ 32.68 18.13
ELECTRICIAN.....\$ 37.15 28.48

ELEC0540-005 01/01/2024

CARROLL (Northern half, including Fox, Harrison, Rose & Washington Townships), COLUMBIANA (Knox Township), HOLMES, MAHONING (Smith Township), STARK, TUSCARAWAS (North of Auburn, Clay, Rush & York Townships), and WAYNE (South of Baughman, Chester, Green & Wayne Townships) COUNTIES

Rates Fringes

ELECTRICIAN.....\$ 36.96 28.18

ELEC0573-003 05/27/2024

ASHTABULA (Colebrook, Wayne, Williamsfield, Orwell & Windsor Townships), GEAUGA (Auburn, Middlefield, Parkman & Troy Townships), MAHONING (Milton Township), PORTAGE (Charlestown, Edinburg, Freedom, Hiram, Nelson, Palmyra, Paris & Windham Townships), and TRUMBULL (Except Liberty & Hubbard Townships)

Rates Fringes

ELECTRICIAN.....\$ 40.40 22.20

ELEC0575-001 05/29/2023

ADAMS, FAYETTE, HIGHLAND, HOCKING, JACKSON (Bloomfield, Franklin, Hamilton, Jefferson, Lick, Madison, Scioto, Coal, Jackson, Liberty, Milton & Washington Townships), PICKAWAY (Deer Creek, Perry, Pickaway, Salt Creek & Wayne Townships), PIKE (Beaver, Benton, Jackson, Mifflin, Pebble, PeePee, Perry, Seal, Camp Creek, Newton, Scioto, Sunfish, Union & Marion Townships), ROSS, SCIOTO & VINTON (Clinton, Eagle, Elk, Harrison, Jackson, Richland & Swan Townships)

	Rates	Fringes
ELECTRICIAN.....	\$ 37.00	22.26

ELEC0648-001 08/29/2023

BUTLER and WARREN COUNTIES (Deerfield, Hamilton, Harlan, Massie, Salem, Turtle Creek, Union & Washington Townships)

	Rates	Fringes
CABLE SPLICER.....	\$ 30.50	18.23
ELECTRICIAN.....	\$ 34.00	21.98

ELEC0673-004 05/27/2024

ASHTABULA (Excluding Orwell, Colebrook, Williamsfield, Wayne & Windsor Townships), GEAUGA (Burton, Chardon, Claridon, Hambden, Huntsburg, Montville, Munson, Newbury & Thompson Townships) and LAKE COUNTIES

	Rates	Fringes
CABLE SPLICER.....	\$ 33.81	21.47
ELECTRICIAN.....	\$ 39.64	23.86

ELEC0683-002 05/29/2023

CHAMPAIGN, CLARK, DELAWARE, FAIRFIELD, FRANKLIN, MADISON, PICKAWAY (Circleville, Darby, Harrison, Jackson, Madison, Monroe, Muhlenberg, Scioto, Walnut & Washington Townships), and UNION COUNTIES

	Rates	Fringes
CABLE SPLICER.....	\$ 38.75	24.19
ELECTRICIAN.....	\$ 37.75	24.16

ELEC0688-003 05/30/2022

ASHLAND, CRAWFORD, HURON (Richmond, New Haven, Ripley & Greenwich Townships), KNOX (Liberty, Clinton, Union, Howard, Monroe, Middleberry, Morris, Wayne, Berlin, Pike, Brown & Jefferson Townships), MARION, MORROW, RICHLAND and WYANDOT (Sycamore, Crane, Eden, Pitt, Antrim & Tymochtee Townships) COUNTIES

Rates	Fringes
-------	---------

ELECTRICIAN.....\$ 32.30 21.83

ELEC0972-002 06/01/2023

ATHENS, MEIGS, MONROE, MORGAN, NOBLE, VINTON (Brown, Knox, Madison, Vinton & Wilkesville Townships), and WASHINGTON COUNITIES

Rates Fringes

CABLE SPLICER.....\$ 35.70 30.26
ELECTRICIAN.....\$ 35.45 30.25

ELEC1105-001 05/29/2023

COSHOCTON, GUERNSEY, KNOX (Jackson, Clay, Morgan, Miller, Milford, Hilliar, Butler, Harrison, Pleasant & College Townships), LICKING, MUSKINGUM, PERRY, and TUSCARAWAS (Auburn, York, Clay, Jefferson, Rush, Oxford, Washington, Salem, Perry & Bucks Townships) COUNTIES

Rates Fringes

ELECTRICIAN.....\$ 36.45 24.22

ENGI0018-003 05/01/2024

ASHTABULA, CUYAHOGA, ERIE, GEAUGA, LAKE, LORAIN, MEDINA, PORTAGE, and SUMMIT COUNTIES

Rates Fringes

POWER EQUIPMENT OPERATOR

GROUP 1.....\$ 45.63 16.41
GROUP 2.....\$ 45.53 16.41
GROUP 3.....\$ 44.49 16.41
GROUP 4.....\$ 43.27 16.41
GROUP 5.....\$ 37.98 16.41
GROUP 6.....\$ 46.63 16.41
GROUP 7.....\$ 46.63 16.41

OPERATING ENGINEER CLASSIFICATIONS

GROUP 1 - Air Compressor on Steel Erection; Barrier Moving Machine; Boiler Operator on Compressor or Generator when mounted on a Rig; Cableway; Combination Concrete Mixer & Tower; Concrete Plant (over 4 yd. Capacity); Concrete Pump; Crane (All Types, Including Boom Truck, Cherry Picker); Crane-Compact, Track or Rubber over 4,000 lbs. capacity; Cranes-Self Erecting, Stationary, Track or Truck (All Configurations); Derrick; Dragline; Dredge (Dipper, Clam or

Suction); Elevating Grader or Euclid Loader; Floating Equipment (All Types); Gradall; Helicopter Crew (Operator-Hoist or Winch); Hoe (all types); Hoisting Engine on Shaft or Tunnel Work; Hydraulic Gantry (Lifting System); Industrial-Type Tractor; Jet Engine Dryer (D8 or D9) Diesel Tractor; Locomotive (Standard Gauge); Maintenance Operator Class A; Mixer, Paving (Single or Double Drum); Mucking Machine; Multiple Scraper; Piledriving Machine (All Types); Power Shovel; Prentice Loader; Quad 9 (Double Pusher); Rail Tamper (with auto lifting & aligning device); Refrigerating Machine (Freezer Operation); Rotary Drill, on Caisson work; Rough Terrain Fork Lift with Winch/Hoist; Side-Boom; Slip-Form Paver; Tower Derrick; Tree Shredder; Trench Machine (Over 24" wide); Truck Mounted Concrete Pump; Tug Boat; Tunnel Machine and/or Mining Machine; Wheel Excavator; and Asphalt Plant Engineer (Cleveland District Only).

GROUP 2 - Asphalt Paver; Automatic Subgrader Machine, Self-Propelled (CMI Type); Bobcat Type and/or Skid Steer Loader with Hoe Attachment Greater than 7,000 lbs.; Boring Machine More than 48"; Bulldozer; Endloader; Horizontal Directional Drill (Over 50,000 ft lbs thrust); Hydro Milling Machine; Kolman-type Loader (production type-Dirt); Lead Greaseman; Lighting & Traffic Signal Installation Equipment (includes all groups or classifications); Material Transfer Equipment (Shuttle Buggy) Asphalt; Pettibone-Rail Equipment; Power Grader; Power Scraper; Push Cat; Rotomill (all), Grinders & Planers of All types; Trench Machine (24" wide & under); Vermeer type Concrete Saw; and Maintenance Operators (Portage and Summit Counties Only).

GROUP 3 - A-Frame; Air Compressor on Tunnel Work (low pressure); Asphalt Plant Engineer (Portage and Summit Counties Only); Bobcat-type and/or Skid Steer Loader with or without Attachments; Highway Drills (all types); Locomotive (narrow gauge); Material Hoist/Elevator; Mixer, Concrete (more than one bag capacity); Mixer, one bag capacity (Side Loader); Power Boiler (Over 15 lbs. Pressure) Pump Operator installing & operating Well Points; Pump (4" & over discharge); Roller, Asphalt; Rotovator (lime soil stabilizer); Switch & Tie Tampers (without lifting & aligning device); Utility Operator (Small equipment); Welding Machines; and Railroad Tie Inserter/Remover; Articulating/straight bed end dumps if assigned (minus \$4.00 per hour).

GROUP 4 - Backfiller; Ballast Re-locator; Bars, Joint & Mesh Installing Machine; Batch Plant; Boring Machine Operator (48" or less); Bull Floats; Burlap & Curing Machine; Concrete Plant (capacity 4 yd. & under); Concrete Saw (Multiple); Conveyor (Highway); Crusher; Deckhand; Farm-type Tractor with attachments (highway); Finishing

Machine; Fireperson, Floating Equipment (all types); Forklift; Form Trencher; Hydro Hammer expect masonry; Hydro Seeder; Pavement Breaker; Plant Mixer; Post Driver; Post Hole Digger (Power Auger); Power Brush Burner; Power Form Handling Equipment; Road Widening Trencher; Roller (Brick, Grade & Macadam); Self-Propelled Power Spreader; Self-Propelled Power Subgrader; Steam Fireperson; Tractor (Pulling Sheepfoot, Roller or Grader); and Vibratory Compactor with Integral Power.

GROUP 5 - Compressor (Portable, Sewer, Heavy & Highway); Drum Fireperson (Asphalt Plant); Generator; Masonry Fork Lift; Inboard-Outboard Motor Boat Launch; Oil Heater (asphalt plant); Oiler/Helper; Power Driven Heater; Power Sweeper & Scrubber; Pump (under 4" discharge); Signalperson; Tire Repairperson; VAC/ALLS; Cranes - Compact, track or rubber under 4,000 pound capacity; fueling and greasing; and Chainmen.

GROUP 6 - Master Mechanic & Boom from 150 to 180.

GROUP 7 - Boom from 180 and over.

 ENGI0018-004 05/01/2024

ADAMS, ALLEN, ASHLAND, ATHENS, AUGLAIZE, BELMONT, BROWN, BUTLER, CARROLL, CHAMPAIGN, CLARK, CLERMONT, CLINTON, COSHOCTON, CRAWFORD, DARKE, DEFIANCE, DELAWARE, FAIRFIELD, FAYETTE, FRANKLIN, FULTON, GALLIA, GREENE, GUERNSEY, HAMILTON, HANCOCK, HARDIN, HARRISON, HENRY, HIGHLAND, HOCKING, HOLMES, HURON, JACKSON, JEFFERSON, KNOX, LAWRENCE, LICKING, LOGAN, LUCAS, MADISON, MARION, MEIGS, MERCER, MIAMI, MONROE, MONTGOMERY, MORGAN, MORROW, MUSKINGUM, NOBLE, OTTAWA, PAULDING, PERRY, PICKAWAY, PIKE, PREBLE, PUTNAM, RICHLAND, ROSS, SANDUSKY, SCIOTO, SENECA, SHELBY, STARK, TUSCARAWAS, UNION, VAN WERT, VINTON, WARREN, WASHINGTON, WAYNE, WILLIAMS, WOOD, and YANDOT COUNTIES

Rates Fringes

POWER EQUIPMENT OPERATOR

GROUP 1.....	\$ 44.14	16.41
GROUP 2.....	\$ 44.02	16.41
GROUP 3.....	\$ 42.98	16.41
GROUP 4.....	\$ 41.80	16.41
GROUP 5.....	\$ 36.34	16.41
GROUP 6.....	\$ 45.14	16.41
GROUP 7.....	\$ 45.14	16.41

OPERATING ENGINEER CLASSIFICATIONS

GROUP 1 - Air Compressor on Steel Erection; Barrier Moving

Machine; Boiler Operator on Compressor or Generator when mounted on a Rig; Cableway; Combination Concrete Mixer & Tower; Concrete Plant (over 4 yd. Capacity); Concrete Pump; Crane (All Types, Including Boom Truck, Cherry Picker); Crane-Compact, Track or Rubber over 4,000 lbs. capacity; Cranes-Self Erecting, Stationary, Track or Truck (All Configurations); Derrick; Dragline; Dredge (Dipper, Clam or Suction); Elevating Grader or Euclid Loader; Floating Equipment (All Types); Gradall; Helicopter Crew (Operator-Hoist or Winch); Hoe (all types); Hoisting Engine on Shaft or Tunnel Work; Hydraulic Gantry (Lifting System); Industrial-Type Tractor; Jet Engine Dryer (D8 or D9) Diesel Tractor; Locomotive (Standard Gauge); Maintenance Operator Class A; Mixer, Paving (Single or Double Drum); Mucking Machine; Multiple Scraper; Piledriving Machine (All Types); Power Shovel; Prentice Loader; Quad 9 (Double Pusher); Rail Tamper (with auto lifting & aligning device); Refrigerating Machine (Freezer Operation); Rotary Drill, on Caisson work; Rough Terrain Fork Lift with Winch/Hoist; Side-Boom; Slip-Form Paver; Tower Derrick; Tree Shredder; Trench Machine (Over 24" wide); Truck Mounted Concrete Pump; Tug Boat; Tunnel Machine and/or Mining Machine; and Wheel Excavator.

GROUP 2 - Asphalt Paver; Automatic Subgrader Machine, Self-Propelled (CMI Type); Bobcat Type and/or Skid Steer Loader with Hoe Attachment Greater than 7,000 lbs.; Boring Machine More than 48"; Bulldozer; Endloader; Hydro Milling Machine; Horizontal Directional Drill (over 50,000 ft. lbs. thrust); Kolman-type Loader (production type-Dirt); Lead Greaseman; Lighting & Traffic Signal Installation Equipment (includes all groups or classifications); Material Transfer Equipment (Shuttle Buggy) Asphalt; Pettibone-Rail Equipment; Power Grader; Power Scraper; Push Cat; Rotomill (all), Grinders & Planers of All types; Trench Machine (24" wide & under); and Vermeer type Concrete Saw.

GROUP 3 - A-Frame; Air Compressor on Tunnel Work (low pressure); Asphalt Plant Engineer; Bobcat-type and/or Skid Steer Loader with or without Attachments; Highway Drills (all types); Locomotive (narrow gauge); Material Hoist/Elevator; Mixer, Concrete (more than one bag capacity); Mixer, one bag capacity (Side Loader); Power Boiler (Over 15 lbs. Pressure) Pump Operator installing & operating Well Points; Pump (4" & over discharge); Railroad Tie Inserter/Remover; Roller, Asphalt; Rotovator (lime soil stabilizer); Switch & Tie Tampers (without lifting & aligning device); Utility Operator (Small equipment); and Welding Machines; Articulating/straight bed end dumps if assigned (minus \$4.00 per hour).

GROUP 4 - Backfiller; Ballast Re-locator; Bars, Joint & Mesh Installing Machine; Batch Plant; Boring Machine Operator (48" or less); Bull Floats; Burlap & Curing Machine;

Concrete Plant (capacity 4 yd. & under); Concrete Saw (Multiple); Conveyor (Highway); Crusher; Deckhand; Farm-type Tractor with attachments (highway); Finishing Machine; Fireperson, Floating Equipment (all types); Fork Lift; Form Trencher; Hydro Hammer expect masonry; Hydro Seeder; Pavement Breaker; Plant Mixer; Post Driver; Post Hole Digger (Power Auger); Power Brush Burner; Power Form Handling Equipment; Road Widening Trencher; Roller (Brick, Grade & Macadam); Self-Propelled Power Spreader; Self-Propelled Power Subgrader; Steam Fireperson; Tractor (Pulling Sheepfoot, Roller or Grader); and Vibratory Compactor with Integral Power.

GROUP 5 - Compressor (Portable, Sewer, Heavy & Highway); Drum Fireperson (Asphalt Plant); Generator; Masonary Forklift; Inboard-Outboard Motor Boat Launch; Oil Heater (asphalt plant); Oiler/Helper; Power Driven Heater; Power Sweeper & Scrubber; Pump (under 4" discharge); Signalperson; Tire Repairperson; VAC/ALLS; Cranes - Compact, track or rubber under 4,000 pound capacity; fueling and greasing; and Chainmen.

GROUP 6 - Master Mechanic & Boom from 150 to 180.

GROUP 7 - Boom from 180 and over.

 ENGI0066-023 06/01/2023

COLUMBIANA, MAHONING & TRUMBULL COUNTIES

Rates Fringes

POWER EQUIPMENT OPERATOR	
ASBESTOS; HAZARDOUS/TOXIC WASTE PROJECTS	
GROUP 1 - A & B.....	\$ 44.63 24.30
ASBESTOS; HAZARDOUS/TOXIC WASTE PROJECTS	
GROUP 2 - A & B.....	\$ 44.30 24.30
ASBESTOS; HAZARDOUS/TOXIC WASTE PROJECTS	
GROUP 3 - A & B.....	\$ 38.47 24.30
ASBESTOS; HAZARDOUS/TOXIC WASTE PROJECTS	
GROUP 4 - A & B.....	\$ 34.52 24.30
ASBESTOS; HAZARDOUS/TOXIC WASTE PROJECTS	
GROUP 5 - A & B.....	\$ 31.13 24.30
HAZARDOUS/TOXIC WASTE PROJECTS	
GROUP 1 - C & D.....	\$ 40.91 24.30
HAZARDOUS/TOXIC WASTE PROJECTS	

GROUP 2 - C & D.....\$ 40.61	24.30
HAZARDOUS/TOXIC WASTE PROJECTS	
GROUP 3 - C & D.....\$ 35.27	24.30
HAZARDOUS/TOXIC WASTE PROJECTS	
GROUP 4 - C & D.....\$ 31.65	24.30
HAZARDOUS/TOXIC WASTE PROJECTS	
GROUP 5 - C & D.....\$ 28.53	24.30
ALL OTHER WORK	
GROUP 1.....\$ 37.19	24.30
ALL OTHER WORK	
GROUP 2.....\$ 36.92	24.30
ALL OTHER WORK	
GROUP 3.....\$ 32.06	24.30
ALL OTHER WORK	
GROUP 4.....\$ 28.77	24.30
ALL OTHER WORK	
GROUP 5.....\$ 25.94	24.30

GROUP 1 - Rig, Pile Driver or Caisson Type; & Rig, Pile Hydraulic Unit Attached

GROUP 2 - Asphalt Heater Planer; Backfiller with Drag Attachment; Backhoe; Backhoe with Shear attached; Backhoe-Rear Pivotal Swing; Batch Plant-Central Mix Concrete; Batch Plant, Portable concrete; Berm Builder-Automatic; Boat Derrick; Boat-Tug; Boring Machine Attached to Tractor; Bullclam; Bulldozer; C.M.I. Road Builder & Similar Type; Cable Placer & Layer; Carrier-Straddle; Carryall-Scraper or Scoop; Chicago Boom; Compactor with Blade Attached; Concrete Saw (Vermeer or similar type); Concrete Spreader Finisher; Combination, Bidwell Machine; Crane; Crane-Electric Overhead; Crane-Rough Terrain; Crane-Side Boom; Crane-Truck; Crane-Tower; Derrick-Boom; Derrick-Car; Digger-Wheel (Not trencher or road widener); Double Nine; Drag Line; Dredge; Drill-Kenny or Similar Type; Easy Pour Median Barrier Machine (or similar type); Electromatic; Frankie Pile; Gradall; Grader; Gurry; Self-Propelled; Heavy Equipment Robotics Operator/Mechanic; Hoist-Monorail; Hoist-Stationary & Mobile Tractor; Hoist, 2 or 3 drum; Horizontal Directional Drill Operator; Jackall; Jumbo Machine; Kocal & Kuhlman; Land-Seagoing Vehicle; Loader, Elevating; Loader, Front End; Loader, Skid Steer; Locomotive; Mechanic/Welder; Metro Chip Harvester with Boom; Mucking Machine; Paver-Asphalt Finishing Machine; Paver-Road Concrete; Paver-Slip Form (C.M.I. or similar); Place Crete Machine with Boom; Post Driver (Carrier mounted); Power Driven Hydraulic Pump & Jack (When used in Slip Form or Lift Slab Construction); Pump Crete Machine; Regulator-Ballast; Hydraulic Power Unit not attached to Rig for Pile Drillings; Rigs-Drilling; Roto Mill or similar

Full Lane (8' Wide & Over); Roto Mill or similar type (Under 8'); Shovel; Slip Form Curb Machine; Speedwing; Spikemaster; Stonecrusher; Tie Puller & Loader; Tie Tamper; Tractor-Double Boom; Tractor with Attachments; Truck-Boom; Truck-Tire; Trench Machine; Tunnel Machine (Mark 21 Java or similar); & Whirley (or similar type)

GROUP 3 - Asphalt Plant; Bending Machine (Pipeline or similar type); Boring machine, Motor Driven; Chip Harvester without Boom; Cleaning Machine, Pipeline Type; Coating Machine, Pipeline Type; Compactor; Concrete Belt Placer; Concrete Finisher; Concrete Planer or Asphalt; Concrete Spreader; Elevator; Fork Lift (Home building only); Fork lift & Lulls; Fork Lift Walk Behind (Hoisting over 1 buck high); Form Line Machine; Grease Truck operator; Grout Pump; Gunnite Machine; Horizontal Directional Drill Locator; Single Drum Hoist with or without Tower; Huck Bolting Machine; Hydraulic Scaffold (Hoisting building materials); Paving Breaker (Self-propelled or Ridden); Pipe Dream; Pot Fireperson (Power Agitated); Refrigeration Plant; Road Widener; Roller; Sasgen Derrick; Seeding Machine; Soil Stabilizer (Pump type); Spray Cure Machine, Self-Propelled; Straw Blower Machine; Sub-Grader; Tube Finisher or Broom C.M.I. or similar type; & Tugger Hoist

GROUP 4 - Air Curtain Destructor & Similar Type; Batch Plant-Job Related; Boiler Operator; Compressor; Conveyor; Curb Builder, self-propelled; Drill Wagon; Generator Set; Generator-Steam; Heater-Portable Power; Hydraulic Manipulator Crane; Jack-Hydraulic Power driven; Jack-Hydraulic (Railroad); Ladavator; Minor Machine Operator; Mixer-Concrete; Mulching Machine; Pin Puller; Power Broom; Pulverizer; Pump; Road Finishing Machine (Pull Type); Saw-Concrete-Self-Propelled (Highway Work); Signal Person; Spray Cure Machine-Motor Powered; Stump Cutter; Tractor; Trencher Form; Water Blaster; Steam Jenny; Syphon; Vibrator-Gasoline; & Welding Machine

GROUP 5 - Brakeperson; Fireperson; & Oiler

IRON0017-002 05/01/2024

ASHTABULA (North of Route 6, starting at the Geauga County Line, proceeding east to State Route 45), CUYAHOGA, ERIE (Eastern 2/3), GEAUGA, HURON (East of a line drawn from the north border through Monroeville & Willard), LAKE, LORAIN, MEDINA (North of Old Rte. #224), PORTAGE (West of a line from Middlefield to Shalersville to Deerfield), and SUMMIT (North of Old Rte. #224, including city limits of Barberton) COUNTIES

Rates Fringes

IRONWORKER

Ornamental, Reinforcing, &
Structural.....\$ 36.83 29.01

IRON0017-010 05/01/2024

ASHTABULA (Eastern part from Lake Erie on the north to route
#322 on the south to include Conneaut, Kingsville, Sheffield,
Denmark, Dorset, Cherry Valley, Wayne, Monroe, Pierpont,
Richmond, Andover & Williamsfield Townships)

Rates Fringes

IRONWORKER

Structural, including
metal building erection &
Reinforcing.....\$ 36.83 29.01

IRON0044-001 06/01/2022

ADAMS (Western Part), BROWN, BUTLER (Southern Part), CLERMONT,
CLINTON (South of a line drawn from Blanchester to Lynchburg),
HAMILTON, HIGHLAND (Excluding eastern one-fifth & portion of
county inside lines drawn from Marshall to Lynchburg from the
northern county line through E. Monroe to Marshall) and WARREN
(South of a line drawn from Blanchester through Morrow to the
west county line) COUNTIES

Rates Fringes

IRONWORKER, REINFORCING.....\$ 32.37 22.30
Beyond 30-mile radius of
Hamilton County Courthouse..\$ 28.67 21.20
Up to & including 30-mile
radius of Hamilton County
Courthouse.....\$ 27.60 20.70

IRON0044-002 06/01/2024

CLINTON (South of a line drawn from Blanchester to Lynchburg),
HAMILTON, HIGHLAND (Excluding eastern one-fifth & portion of
county inside lines drawn from Marshall to Lynchburg from the
northern county line through E. Monroe to Marshall) & WARREN
(South of a line drawn from Blanchester through Morrow to the
west county line)

Rates Fringes

IRONWORKER

Fence Erector.....\$ 33.60 23.00
Ornamental; Structural.....\$ 35.37 23.00

IRON0055-003 07/01/2024

CRAWFORD (Area Between lines drawn from where Hwy #598 & #30 meet through N. Liberty to the northern border & from said Hwy junction point due west to the border), DEFIANCE (S. of a line drawn from where Rte. #66 meets the northern line through Independence to the eastern county border), ERIE (Western 1/3), FULTON, HANCOCK, HARDIN (North of a line drawn from Maysville to a point 4 miles south of the northern line on the eastern line), HENRY, HURON (West of a line drawn from the northern border through Monroeville & Willard), LUCAS, OTTAWA, PUTNAM (East of a line drawn from the northern border down through Miller City to where #696 meets the southern border), SANDUSKY, SENECA, WILLIAMS (East of a line drawn from Pioneer through Stryker to the southern border), WOOD & WYANDOT (North of Rte. #30)

Rates Fringes

IRONWORKER

Fence Erector.....	\$ 26.40	24.62
Flat Road Mesh.....	\$ 29.77	21.30
Tunnels & Caissons Under Pressure.....	\$ 29.77	21.30
All Other Work.....	\$ 35.50	29.20

IRON0147-002 06/01/2024

ALLEN (Northern half), DEFIANCE (Northern part, excluding south of a line drawn from where Rte. #66 meets the northern line through Independence to the eastern county border), MERCER (Northern half), PAULDING, PUTNAM (Western part, excluding east of a line drawn from the northern border down through Miller City to where #696 meets the southern border), VAN WERT, and WILLIAMS (Western part, excluding east of a line drawn from Pioneer through Stryker to the southern border) COUNTIES

Rates Fringes

IRONWORKER.....	\$ 34.20	26.39
-----------------	----------	-------

IRON0172-002 06/01/2024

CHAMPAIGN (Eastern one-third), CLARK (Eastern one-fourth), COSHOCTON (West of a line beginning at the northwestern county line going through Walhonding & Tunnel Hill to the southern county line), CRAWFORD (South of Rte. #30), DELAWARE, FAIRFIELD, FAYETTE, FRANKLIN, HARDIN (Excluding a line drawn from Roundhead to Maysville), HIGHLAND (Eastern one-fifth), HOCKING, JACKSON (Northern half), KNOX, LICKING, LOGAN (Eastern one-third), MADISON, MARION, MORROW, MUSKINGUM (West of a line

starting at Adams Mill going to Adamsville & going from Adamsville through Blue Rock to the southern border), PERRY, PICKAWAY, PIKE (Northern half), ROSS, UNION, VINTON and WYANDOT (South of Rte. #30) COUNTIES

Rates Fringes

IRONWORKER.....\$ 36.77 22.85

IRON0207-004 06/01/2024

ASHTABULA (Southern part starting at the Geauga County line), COLUMBIANA (E. of a line from Damascus to Highlandtown), MAHONING (N. of Old Route #224), PORTAGE (E. of a line from Middlefield to Shalersville to Deerfield) & TRUMBULL

Rates Fringes

IRONWORKER

Layout; Sheeter.....\$ 35.83 27.41

Ornamental; Reinforcing;

Structural.....\$ 34.83 27.41

Ornamental; Reinforcing.....\$ 28.92 25.61

IRON0290-002 06/01/2024

ALLEN (Southern half), AUGLAIZE, BUTLER (North of a line drawn from east to the west county line going through Oxford, Darrtown & Woodsdale), CHAMPAIGN (Excluding east of a line drawn from Catawla to the point where #68 intersects the northern county line), CLARK (Western two-thirds), CLINTON (Excluding south of a line drawn from Blanchester to Lynchburg), DARKE, GREENE, HIGHLAND (Inside lines drawn from Marshall to Lynchburg & from the northern county line through East Monroe to Marshall), LOGAN (West of a line drawn from West Liberty to where the northern county line meets the western county line of Hardin), MERCER (Southern half), MIAMI, MONTGOMERY, PREBLE, SHELBY & WARREN (Excluding south of a line drawn from Blanchester through Morrow to the western county line) COUNTIES

Rates Fringes

IRONWORKER.....\$ 35.39 24.35

IRON0549-003 12/01/2022

BELMONT, GUERNSEY, HARRISON, JEFFERSON, MONROE & MUSKINGUM (Excluding portion west of a line starting at Adams Mill going to Adamsville and going from Adamsville through Blue Rock to the south border)

Rates Fringes

IRONWORKER.....\$ 35.19 25.66

IRON0550-004 05/01/2024

ASHLAND, CARROLL, COLUMBIANA (W. of a line from Damascus to Highlandtown), COSHOCTON (E. of a line beginning at NW Co. line going through Walhonding & Tunnel Hill to the South Co. line), HOLMES, HURON (S. of Old Rte. #224), MAHONING (S. of Old Rte. #224), MEDINA (S. of Old Rte. #224), PORTAGE (S. of Old Rte. #224), RICHLAND, STARK, SUMMIT (S. of Old Rte. #224, Excluding city limits of Barberton), TUSCARAWAS, & WAYNE

Rates Fringes

Ironworkers:Structural,
Ornamental and Reinforcing.....\$ 34.70 22.88

IRON0769-004 06/01/2024

ADAMS (Eastern Half), GALLIA, JACKSON (Southern Half), LAWRENCE & SCIOTO

Rates Fringes

IRONWORKER.....\$ 37.66 29.24

IRON0787-003 06/01/2024

ATHENS, MEIGS, MORGAN, NOBLE, and WASHINGTON COUNTIES

Rates Fringes

IRONWORKER.....\$ 33.00 24.25

LABO0265-008 05/01/2024

Rates Fringes

LABORER

ASHTABULA, ERIE, HURON,
LORAIN, LUCAS, MAHONING,
MEDINA, OTTAWA, PORTAGE,
SANDUSKY, STARK, SUMMIT,
TRUMBULL & WOOD COUNTIES

GROUP 1.....\$ 35.05 13.70
GROUP 2.....\$ 35.22 13.70
GROUP 3.....\$ 35.55 13.70
GROUP 4.....\$ 36.00 13.70

CUYAHOGA AND GEAUGA		
COUNTIES ONLY: SEWAGE		
PLANTS, WASTE PLANTS,		
WATER TREATMENT		
FACILITIES, PUMPING		
STATIONS, & ETHANOL PLANTS		
CONSTRUCTION.....	\$ 37.66	13.70
CUYAHOGA, GEAUGA & LAKE		
COUNTIES		
GROUP 1.....	\$ 36.28	13.70
GROUP 2.....	\$ 36.45	13.70
GROUP 3.....	\$ 36.78	13.70
GROUP 4.....	\$ 37.23	13.70
REMAINING COUNTIES OF OHIO		
GROUP 1.....	\$ 35.52	14.45
GROUP 2.....	\$ 35.69	14.45
GROUP 3.....	\$ 36.02	14.45
GROUP 4.....	\$ 36.47	14.45

LABORER CLASSIFICATIONS

GROUP 1 - Asphalt Laborer; Carpenter Tender; Concrete Curing Applicator; Dump Man (Batch Truck); Guardrail and Fence Installer; Joint Setter; Laborer (Construction); Landscape Laborer; Mesh Handlers & Placer; Right-of-way Laborer; Riprap Laborer & Grouter; Scaffold Erector; Seal Coating; Surface Treatment or Road Mix Laborer; Sign Installer; Slurry Seal; Utility Man; Bridge Man; Handyman; Waterproofing Laborer; Flagperson; Hazardous Waste (level D); Diver Tender; Zone Person & Traffic Control

GROUP 2 - Asphalt Raker; Concrete Puddler; Kettle Man Pipeline); Machine Driven Tools (Gas, Electric, Air); Mason Tender; Brick Paver; Mortar Mixer; Power Buggy or Power Wheelbarrow; Paint Striper; Sheeting & Shoring Man; Surface Grinder Man; Plastic Fusing Machine Operator; Pug Mill Operator; & Vacuum Devices (wet or dry); Rodding Machine Operator; Diver; Screwman or Paver; Screed Person; Water Blast, Hand Held Wand; Pumps 4" & Under (Gas, Air or Electric) & Hazardous Waste (level C); Air Track and Wagon Drill; Bottom Person; Cofferdam (below 25 ft. deep); Concrete Saw Person; Cutting with Burning Torch; Form Setter; Hand Spiker (Railroad); Pipelayer; Tunnel Laborer (without air) & Caisson; Underground Person (working in Sewer and Waterline, Cleaning, Repairing & Reconditioning); Sandblaster Nozzle Person; & Hazardous Waste (level B)

GROUP 3 - Blaster; Mucker; Powder Person; Top Lander; Wrencher (Mechanical Joints & Utility Pipeline); Yarner; Hazardous Waste (level A); Concrete Specialist; Concrete Crew in Tunnels (With Air-pressurized - \$1.00 premium); Curb Setter & Cutter; Grade Checker; Utility Pipeline Tapper; Waterline; and Caulker

GROUP 4 - Miner (With Air-pressurized - \$1.00 premium); &
Gunitite Nozzle Person

TUNNEL LABORER WITH AIR-PRESSURIZED ADD \$1.00 TO BASE RATE

SIGNAL PERSON WILL RECEIVE THE RATE EQUAL TO THE RATE PAID
THE LABORER CLASSIFICATION FOR WHICH HE OR SHE IS SIGNALING.

PAIN0006-002 05/01/2023

ASHTABULA, CUYAHOGA, GEAUGA, LAKE, LORAIN, PORTAGE (N. of the
East-West Turnpike) & SUMMIT (N. of the East-West Turnpike)

Rates Fringes

PAINTER

COMMERCIAL NEW WORK;
REMODELING; & RENOVATIONS

GROUP 1.....	\$ 30.75	18.95
GROUP 2.....	\$ 31.15	18.95
GROUP 3.....	\$ 31.45	18.95
GROUP 4.....	\$ 37.01	18.95

COMMERCIAL REPAINT

GROUP 1.....	\$ 29.25	18.95
GROUP 2.....	\$ 29.65	18.95
GROUP 3.....	\$ 29.95	18.95

PAINTER CLASSIFICATIONS - COMMERCIAL NEW WORK; REMODELING; &
RENOVATIONS

GROUP 1 - Brush; & Roller

GROUP 2 - Sandblasting & Buffing

GROUP 3 - Spray Painting; Closed Steel Above 55 feet; Bridges
& Open Structural Steel; Tanks - Water Towers; Bridge
Painters; Bridge Riggers; Containment Builders

GROUP 4 - Bridge Blaster

PAINTER CLASSIFICATIONS - COMMERCIAL REPAINT

GROUP 1 - Brush; & Roller

GROUP 2 - Sandblasting & Buffing

GROUP 3 - Spray Painting

PAIN0007-002 07/01/2024

FULTON, HENRY, LUCAS, OTTAWA (Excluding Allen, Bay, Bono,

Catawba Island, Clay Center, Curtice, Danbury, Eagle Beach, Elliston, Elmore, Erie, Fishback, Gem Beach & Genova) & WOOD

Rates Fringes

PAINTER

NEW COMMERCIAL WORK

GROUP 1.....	\$ 31.84	20.79
GROUP 2.....	\$ 32.84	20.79
GROUP 3.....	\$ 32.84	20.79
GROUP 4.....	\$ 32.84	20.79
GROUP 5.....	\$ 32.84	20.79
GROUP 6.....	\$ 32.84	20.79
GROUP 7.....	\$ 32.84	20.79
GROUP 8.....	\$ 32.84	20.79
GROUP 9.....	\$ 32.84	20.79

REPAINT IS 90% OF JR

PAINTER CLASSIFICATIONS

GROUP 1 - Brush; Spray & Sandblasting Pot Tender

GROUP 2 - Refineries & Refinery Tanks; Surfaces 30 ft. or over where material is applied to or labor performed on above ground level (exterior), floor level (interior)

GROUP 3 - Swing Stage & Chair

GROUP 4 - Lead Abatement

GROUP 5 - All Methods of Spray

GROUP 6 - Solvent-Based Catalized Epoxy Materials of 2 or More Component Materials, to include Solvent-Based Conversion Varnish (excluding water based)

GROUP 7 - Spray Solvent Based Material; Sand & Abrasive Blasting

GROUP 8 - Towers; Tanks; Bridges; Stacks Over 30 Feet

GROUP 9 - Epoxy Spray (excluding water based)

PAIN0012-008 05/01/2019

BUTLER COUNTY

Rates Fringes

PAINTER

GROUP 1.....	\$ 21.95	10.20
--------------	----------	-------

GROUP 2.....	\$ 25.30	10.20
GROUP 3.....	\$ 25.80	10.20
GROUP 4.....	\$ 26.05	10.20
GROUP 5.....	\$ 26.30	10.20

PAINTER CLASSIFICATIONS

GROUP 1: Bridge Equipment Tender; Bridge/Containment Builder

GROUP 2: Brush & Roller

GROUP 3: Spray

GROUP 4: Sandblasting; & Waterblasting

GROUP 5: Elevated Tanks; Steeplejack Work; Bridge; & Lead Abatement

PAIN0012-010 05/01/2019

BROWN, CLERMONT, CLINTON, HAMILTON & WARREN

Rates Fringes

PAINTER

HEAVY & HIGHWAY BRIDGES-
GUARDRAILS-LIGHTPOLES-
STRIPING

Bridge Equipment Tender and Containment Builder....	\$ 21.95	10.20
Bridges when highest point of clearance is 60 feet or more; & Lead Abatement Projects.....	\$ 26.30	10.20
Brush & Roller.....	\$ 25.30	10.20
Sandblasting & Hopper Tender; Water Blasting.....	\$ 26.05	10.20
Spray.....	\$ 25.80	10.20

PAIN0093-001 12/01/2023

ATHENS, GUERNSEY, HOCKING, MONROE, MORGAN, NOBLE and
WASHINGTON COUNTIES

Rates Fringes

PAINTER

Bridges; Locks; Dams; Tension Towers; & Energized Substations.....	\$ 35.45	23.69
Power Generating Facilities.	\$ 32.30	23.69

PAIN0249-002 05/01/2024

CLARK, DARKE, GREENE, MIAMI, MONTGOMERY & PREBLE

Rates Fringes

PAINTER

GROUP 1 - Brush & Roller....	\$ 27.15	13.64
GROUP 2 - Swing, Scaffold Bridges; Structural Steel; Open Acid Tank; High Tension Electrical Equipment; & Hot Pipes.....	\$ 27.15	13.64
GROUP 3 - Spray; Sandblast; Steamclean; Lead Abatement.....	\$ 27.90	13.64
GROUP 4 - Steeplejack Work..	\$ 28.10	13.64
GROUP 5 - Coal Tar.....	\$ 28.65	13.64
GROUP 6 - Bridge Equipment Tender & or Containment Builder.....	\$ 35.86	13.64
GROUP 7 - Tanks, Stacks & Towers.....	\$ 31.09	13.64
GROUP 8 - Bridge Blaster, Rigger.....	\$ 38.86	13.64

PAIN0356-002 09/01/2009

KNOX, LICKING, MUSKINGUM, and PERRY

Rates Fringes

PAINTER

Bridge Equipment Tenders and Containment Builders....	\$ 27.93	7.25
Bridges; Blasters; and Riggers.....	\$ 34.60	7.25
Brush and Roller.....	\$ 20.93	7.25
Sandblasting; Steam Cleaning; Waterblasting; and Hazardous Work.....	\$ 25.82	7.25
Spray.....	\$ 21.40	7.25
Structural Steel and Swing Stage.....	\$ 25.42	7.25
Tanks; Stacks; and Towers...	\$ 28.63	7.25

PAIN0438-002 12/01/2023

BELMONT, HARRISON and JEFFERSON COUNTIES

Rates Fringes

PAINTER

Bridges, Locks, Dams, Tension Towers & Energized Substations.....	\$ 36.09	19.49
Power Generating Facilities.....	\$ 32.94	19.49

PAIN0476-001 06/01/2024

COLUMBIANA, MAHONING, and TRUMBULL COUNTIES

Rates	Fringes
-------	---------

PAINTER

GROUP 1.....	\$ 28.39	17.14
GROUP 2.....	\$ 35.02	17.14
GROUP 3.....	\$ 28.60	17.14
GROUP 4.....	\$ 28.89	17.14
GROUP 5.....	\$ 29.04	17.14
GROUP 6.....	\$ 29.29	17.14
GROUP 7.....	\$ 30.39	17.14

PAINTER CLASSIFICATIONS:

GROUP 1: Painters, Brush & Roller

GROUP 2: Bridges

GROUP 3: Structural Steel

GROUP 4: Spray, Except Bar Joist/Deck

GROUP 5: Epoxy/Mastic; Spray- Bar Joist/Deck; Working Above
50 Feet; and Swingstages

GROUP 6: Tanks; Sandblasting

GROUP 7: Towers; Stacks

PAIN0555-002 11/01/2023

ADAMS, HIGHLAND, JACKSON, PIKE & SCIOTO

Rates	Fringes
-------	---------

PAINTER

GROUP 1.....	\$ 32.18	20.29
GROUP 2.....	\$ 33.81	20.29
GROUP 3.....	\$ 35.44	20.29
GROUP 4.....	\$ 38.63	20.29

PAINTER CLASSIFICATIONS

GROUP 1 - Containment Builder

GROUP 2 - Brush; Roller; Power Tools, Under 40 feet

GROUP 3 - Sand Blasting; Spray; Steam Cleaning; Pressure Washing; Epoxy & Two Component Materials; Lead Abatement; Hazardous Waste; Toxic Materials; Bulk & Storage Tanks of 25,000 Gallon Capacity or More; Elevated Tanks

GROUP 4 - Stacks; Bridges

PAIN0639-001 05/01/2011

Rates Fringes

Sign Painter & Erector.....\$ 20.61 3.50+a+b+c

FOOTNOTES: a. 7 Paid Holidays: New Year's Day; Memorial Day; July 4th; Labor Day; Thanksgiving Day; Christmas Day & 1 Floating Day

b. Vacation Pay: After 1 year's service - 5 days' paid vacation; After 2, but less than 10 years' service - 10 days' paid vacation; After 10, but less than 20 years' service - 15 days' paid vacation; After 20 years' service - 20 days' paid vacation

c. Funeral leave up to 3 days maximum paid leave for death of mother, father, brother, sister, spouse, child, mother-in-law, father-in-law, grandparent and inlaw provided employee attends funeral

PAIN0788-002 06/01/2024

ASHLAND, CRAWFORD, ERIE, HANCOCK, HURON, MARION, MORROW, OTTAWA (Allen, Bay, Bono, Catawba Island, Clay Center, Curtice, Danbury, Eagle Beach, Elliston, Elmore, Erie, Fishback, Gem Beach & Genoa), RICHLAND, SANDUSKY, SENECA & WYANDOT

Rates Fringes

PAINTER

Brush & Roller.....\$ 29.13 17.52
Structural Steel.....\$ 30.73 17.52

WINTER REPAINT: Between December 1 to March 31 - 90%JR

\$.50 PER HOUR SHALL BE ADDED TO THE RATE OF PAY FOR THE CLASSIFICATION OF WORK:

While working swingstage, boatswain chair, needle beam and horizontal cable. While operating sprayguns, sandblasting, cobbasting and high pressure waterblasting (4000psi).

\$1.00 PER HOUR SHALL BE ADDED TO THE RATE OF PAY FOR THE

CLASSIFICATION OF WORK:

For the application of catalized epoxy, including latex epoxy that is deemed hazardous, lead abatement, or for work or material where special precautions beyond normal work duties must be taken. For working on stacks, tanks, and towers over 40 feet in height.

PAIN0813-005 12/01/2008

GALLIA, LAWRENCE, MEIGS & VINTON

	Rates	Fringes
PAINTER		
Base Rate.....	\$ 24.83	10.00
Bridges, Locks, Dams & Tension Towers.....	\$ 27.83	10.00

PAIN0841-001 06/01/2023

MEDINA, PORTAGE (South of and including Ohio Turnpike), and
SUMMIT (South of and including Ohio Turnpike) COUNTIES

	Rates	Fringes
Painters:		
GROUP 1.....	\$ 30.18	15.50
GROUP 2.....	\$ 30.83	15.50
GROUP 3.....	\$ 30.93	15.50
GROUP 4.....	\$ 31.03	15.50
GROUP 5.....	\$ 31.43	15.50
GROUP 6.....	\$ 39.20	11.75
GROUP 7.....	\$ 31.68	15.50

PAINTER CLASSIFICATIONS:

GROUP 1 - Brush, Roller & Paperhanger

GROUP 2 - Epoxy Application

GROUP 3 - Swing Scaffold, Bosum Chair, & Window Jack

GROUP 4 - Spray Gun Operator of Any & All Coatings

GROUP 5 - Sandblast, Painting of Standpipes, etc. from
Scaffolds, Bridge Work and/or Open Structural Steel,
Standpipes and/or Water Towers

GROUP 6 - Public & Commerce Transportation, Steel or
Galvanized, Bridges, Tunnels & Related Support Items
(concrete)

GROUP 7 - Synthetic Exterior, Drywall Finisher and/or Taper,
Drywall Finisher and Follow-up Man Using Automatic Tools

PAIN0841-002 06/01/2023

CARROLL, COSHOCTON, HOLMES, STARK, TUSCARAWAS & WAYNE

Rates Fringes

PAINTER

Bridges; Towers, Poles & Stacks; Sandblasting Steel; Structural Steel & Metalizing.....	\$ 31.43	15.50
Brush & Roller.....	\$ 30.18	15.50
Spray; Tank Interior & Exterior.....	\$ 31.03	15.50

* PAIN1020-002 07/01/2024

ALLEN, AUGLAIZE, CHAMPAIGN, DEFIANCE, HARDIN, LOGAN, MERCER,
PAULDING, PUTNAM, SHELBY, VAN WERT, and WILLIAMS COUNTIES

Rates Fringes

PAINTER

Brush & Roller.....	\$ 26.54	17.66
Drywall Finishing & Taping..	\$ 27.29	17.66
Lead Abatement.....	\$ 28.29	17.66
Spray, Sandblasting Pressure Cleaning, & Refinery.....	\$ 27.29	17.66
Swing Stage, Chair, Spiders, & Cherry Pickers...	\$ 26.79	17.66
Wallcoverings.....	\$ 27.29	17.66

All surfaces 40 ft. or over where material is applied to or
labor performed on, above ground level (exterior), floor
level (interior) - \$.50 premium

Applying Coal Tar Products - \$1.00 premium

PAIN1275-002 05/01/2024

DELAWARE, FAIRFIELD, FAYETTE, FRANKLIN, MADISON, PICKAWAY, ROSS
& UNION

Rates Fringes

PAINTER

Bridges.....	\$ 36.26	14.91
Brush; Roller.....	\$ 30.65	14.91
Sandblasting; Steamcleaning; Waterblasting (3500 PSI or Over)& Hazardous Work.....	\$ 31.35	14.91
Spray.....	\$ 31.15	14.91
Stacks; Tanks; & Towers.....	\$ 33.46	14.91
Structural Steel & Swing Stage.....	\$ 29.50	14.91

PLAS0109-001 06/01/2024

MEDINA, PORTAGE, STARK, and SUMMIT COUNTIES

Rates Fringes

PLASTERER.....	\$ 31.70	23.63
----------------	----------	-------

PLAS0109-003 06/01/2024

CARROLL, HOLMES, TUSCARAWAS, and WAYNE COUNTIES

Rates Fringes

PLASTERER.....	\$ 31.70	23.63
----------------	----------	-------

* PLAS0132-002 07/01/2024

BROWN, BUTLER, CLERMONT, HAMILTON, HIGHLAND, WARREN COUNTIES

Rates Fringes

PLASTERER.....	\$ 30.40	16.54
----------------	----------	-------

PLAS0404-002 05/01/2018

ASHTABULA, CUYAHOGA, GEAUGA, AND LAKE COUNTIES

Rates Fringes

PLASTERER.....	\$ 29.63	17.11
----------------	----------	-------

PLAS0404-003 05/01/2018

LORAIN COUNTY

Rates Fringes

PLASTERER.....	\$ 28.86	17.11
----------------	----------	-------

PLAS0526-022 05/01/2018

COLUMBIANA, MAHONING, and TRUMBULL COUNTIES

Rates Fringes

PLASTERER.....\$ 28.86 17.11

PLAS0526-023 05/01/2018

BELMONT, HARRISON, and JEFFERSON COUNTIES

Rates Fringes

PLASTERER.....\$ 28.21 17.11

PLAS0886-001 07/01/2024

FULTON, HANCOCK, HENRY, LUCAS, PUTNAM, and WOOD COUNTIES

Rates Fringes

PLASTERER.....\$ 33.73 23.25

PLAS0886-003 07/01/2024

Rates Fringes

PLASTERER.....\$ 33.73 23.25

PLAS0886-004 07/01/2024

Rates Fringes

PLASTERER.....\$ 33.73 23.25

PLUM0042-002 07/01/2024

ASHLAND, CRAWFORD, ERIE, HURON, KNOX, LORAIN, MORROW, RICHLAND
& WYANDOT

Rates Fringes

Plumber, Pipefitter,
Steamfitter.....\$ 40.62 25.67

PLUM0050-002 07/01/2024

DEFIANCE, FULTON, HANCOCK, HENRY, LUCAS, OTTAWA, PAULDING,
PUTNAM, SANDUSKY, SENECA, WILLIAMS & WOOD

Rates Fringes

Plumber, Pipefitter,

Steamfitter.....\$ 49.70 30.76

PLUM0055-003 05/01/2024

ASHTABULA, CUYAHOGA, GEAUGA, LAKE, MEDINA (N. of Rte. #18 & Smith Road) & SUMMIT (N. of Rte. #303, including the corporate limits of the city of Hudson)

Rates Fringes

PLUMBER.....\$ 42.36 29.90

PLUM0083-001 07/01/2023

BELMONT & MONROE (North of Rte. #78)

Rates Fringes

Plumber and Steamfitter.....\$ 35.94 37.35

PLUM0094-002 05/01/2023

CARROLL (Northen Half), STARK, and WAYNE COUNTIES

Rates Fringes

PLUMBER/PIPEFITTER.....\$ 38.03 23.09

PLUM0120-002 04/29/2024

ASHTABULA, CUYAHOGA, GEAUGA, LAKE, LORAIN (the C.E.I. Power House in Avon Lake), MEDINA (N. of Rte. #18) & SUMMIT (N. of #303)

Rates Fringes

PIPEFITTER.....\$ 47.07 28.15

PLUM0162-002 06/01/2024

CHAMPAIGN, CLARK, CLINTON, DARKE, FAYETTE, GREENE, MIAMI, MONTGOMERY & PREBLE

Rates Fringes

Plumber, Pipefitter,
Steamfitter.....\$ 43.05 27.18

PLUM0168-002 06/01/2024

MEIGS, MONROE (South of Rte. #78), MORGAN (South of Rte. #78)

& WASHINGTON

Rates Fringes

PLUMBER/PIPEFITTER.....\$ 39.43 37.29

PLUM0189-002 06/01/2024

DELAWARE, FAIRFIELD, FRANKLIN, HOCKING, LICKING, MADISON,
MARION, PERRY, PICKAWAY, ROSS & UNION

Rates Fringes

Plumber, Pipefitter,
Steamfitter.....\$ 43.25 26.94

PLUM0219-002 06/01/2024

MEDINA (Rte. #18 from eastern edge of Medina Co., west to
eastern corporate limits of the city of Medina, & on the county
road from the west corporate limits of Medina running due west
to and through community of Risley to the western edge of
Medina County - All territory south of this line), PORTAGE, and
SUMMIT (S. of Rte. #303) COUNTIES

Rates Fringes

Plumber and Steamfitter.....\$ 45.37 27.64

PLUM0392-002 06/01/2024

BROWN, BUTLER, CLERMONT, HAMILTON & WARREN

Rates Fringes

PLUMBER/PIPEFITTER.....\$ 40.65 26.75

PLUM0396-001 06/01/2024

COLUMBIANA (Excluding Washington & Yellow Creek Townships &
Liverpool Twp. - Secs. 35 & 36 - West of County Road #427),
MAHONING and TRUMBULL COUNTIES

Rates Fringes

PLUMBER/PIPEFITTER.....\$ 38.45 28.96

PLUM0495-002 06/01/2024

CARROLL (Rose, Monroe, Union, Lee, Orange, Perry & Loudon

Townships), COLUMBIANA (Washington & Yellow Creek Townships & Liverpool Township, Secs. 35 & 36, West of County Rd. #427), COSHOCTON, GUERNSEY, HARRISON, HOLMES, JEFFERSON, MORGAN (South to State Rte. #78 & from McConnellsville west on State Rte. #37 to the Perry County line), MUSKINGUM, NOBLE, and TUSCARAWAS COUNTIES

Rates Fringes

Plumber, Pipefitter,
Steamfitter.....\$ 37.82 36.70

PLUM0577-002 06/01/2024

ADAMS, ATHENS, GALLIA, HIGHLAND, JACKSON, LAWRENCE, PIKE, SCIOTO & VINTON

Rates Fringes

Plumber, Pipefitter,
Steamfitter.....\$ 41.65 27.48

PLUM0776-002 07/01/2024

ALLEN, AUGLAIZE, HARDIN, LOGAN, MERCER, SHELBY and VAN WERT COUNTIES

Rates Fringes

Plumber, Pipefitter,
Steamfitter.....\$ 42.07 29.35

TEAM0377-003 05/01/2024

STATEWIDE, EXCEPT CUYAHOGA, GEAUGA & LAKE

Rates Fringes

TRUCK DRIVER
GROUP 1.....\$ 32.54 16.80
GROUP 2.....\$ 32.96 16.80

TRUCK DRIVER CLASSIFICATIONS

GROUP 1 - Asphalt Distributor; Batch; 4- Wheel Service; 4-Wheel Dump; Oil Distributor & Tandem

GROUP 2 - Tractor-Trailer Combination: Fuel; Pole Trailer; Ready Mix; Semi-Tractor; & Asphalt Oil Spraybar Man When Operated From Cab; 5 Axles & Over; Belly Dump; End Dump; Articulated Dump; Heavy Duty Equipment; Low Boy; & Truck

Mechanic

* TEAM0436-002 05/01/2024

CUYAHOGA, GEAUGA & LAKE

Rates Fringes

TRUCK DRIVER

GROUP 1.....	\$ 32.25	18.95
GROUP 2.....	\$ 33.75	18.95

GROUP 1: Straight & Dump, Straight Fuel

GROUP 2: Semi Fuel, Semi Tractor, Euclids, Darts, Tank, Asphalt Spreaders, Low Boys, Carry-All, Tourna-Rockers, Hi-Lifts, Extra Long Trailers, Semi-Pole Trailers, Double Hook-Up Tractor Trailers including Team Track & Railroad Siding, Semi-Tractor & Tri-Axle Trailer, Tandem Tractor & Tandem Trailer, Tag Along Trailer, Expandable Trailer or Towing Requiring Road Permits, Ready-Mix (Agitator or Non-Agitator), Bulk Concrete Driver, Dry Batch Truck, Articulated End Dump

WELDERS - Receive rate prescribed for craft performing operation to which welding is incidental.

=====

** Workers in this classification may be entitled to a higher minimum wage under Executive Order 14026 (\$17.20) or 13658 (\$12.90). Please see the Note at the top of the wage determination for more information. Please also note that the minimum wage requirements of Executive Order 14026 are not currently being enforced as to any contract or subcontract to which the states of Texas, Louisiana, or Mississippi, including their agencies, are a party.

Note: Executive Order (EO) 13706, Establishing Paid Sick Leave for Federal Contractors applies to all contracts subject to the Davis-Bacon Act for which the contract is awarded (and any solicitation was issued) on or after January 1, 2017. If this contract is covered by the EO, the contractor must provide employees with 1 hour of paid sick leave for every 30 hours they work, up to 56 hours of paid sick leave each year. Employees must be permitted to use paid sick leave for their own illness, injury or other health-related needs, including preventive care; to assist a family member (or person who is like family to the employee) who is ill, injured, or has other health-related needs, including preventive care; or for reasons resulting from, or to assist a family member (or person who is

like family to the employee) who is a victim of, domestic violence, sexual assault, or stalking. Additional information on contractor requirements and worker protections under the EO is available at <https://www.dol.gov/agencies/whd/government-contracts>.

Unlisted classifications needed for work not included within the scope of the classifications listed may be added after award only as provided in the labor standards contract clauses (29CFR 5.5 (a) (1) (iii)).

The body of each wage determination lists the classification and wage rates that have been found to be prevailing for the cited type(s) of construction in the area covered by the wage determination. The classifications are listed in alphabetical order of ""identifiers"" that indicate whether the particular rate is a union rate (current union negotiated rate for local), a survey rate (weighted average rate) or a union average rate (weighted union average rate).

Union Rate Identifiers

A four letter classification abbreviation identifier enclosed in dotted lines beginning with characters other than ""SU"" or ""UAVG"" denotes that the union classification and rate were prevailing for that classification in the survey. Example: PLUM0198-005 07/01/2014. PLUM is an abbreviation identifier of the union which prevailed in the survey for this classification, which in this example would be Plumbers. 0198 indicates the local union number or district council number where applicable, i.e., Plumbers Local 0198. The next number, 005 in the example, is an internal number used in processing the wage determination. 07/01/2014 is the effective date of the most current negotiated rate, which in this example is July 1, 2014.

Union prevailing wage rates are updated to reflect all rate changes in the collective bargaining agreement (CBA) governing this classification and rate.

Survey Rate Identifiers

Classifications listed under the ""SU"" identifier indicate that no one rate prevailed for this classification in the survey and the published rate is derived by computing a weighted average rate based on all the rates reported in the survey for that classification. As this weighted average rate includes all rates reported in the survey, it may include both union and non-union rates. Example: SULA2012-007 5/13/2014. SU indicates the rates are survey rates based on a weighted average

calculation of rates and are not majority rates. LA indicates the State of Louisiana. 2012 is the year of survey on which these classifications and rates are based. The next number, 007 in the example, is an internal number used in producing the wage determination. 5/13/2014 indicates the survey completion date for the classifications and rates under that identifier.

Survey wage rates are not updated and remain in effect until a new survey is conducted.

Union Average Rate Identifiers

Classification(s) listed under the UAVG identifier indicate that no single majority rate prevailed for those classifications; however, 100% of the data reported for the classifications was union data. EXAMPLE: UAVG-OH-0010 08/29/2014. UAVG indicates that the rate is a weighted union average rate. OH indicates the state. The next number, 0010 in the example, is an internal number used in producing the wage determination. 08/29/2014 indicates the survey completion date for the classifications and rates under that identifier.

A UAVG rate will be updated once a year, usually in January of each year, to reflect a weighted average of the current negotiated/CBA rate of the union locals from which the rate is based.

State Adopted Rate Identifiers

Classifications listed under the ""SA"" identifier indicate that the prevailing wage rate set by a state (or local) government was adopted under 29 C.F.R. §1.3(g)-(h). Example: SAME2023-007 01/03/2024. SA reflects that the rates are state adopted. ME refers to the State of Maine. 2023 is the year during which the state completed the survey on which the listed classifications and rates are based. The next number, 007 in the example, is an internal number used in producing the wage determination. 01/03/2024 reflects the date on which the classifications and rates under the ?SA? identifier took effect under state law in the state from which the rates were adopted.

WAGE DETERMINATION APPEALS PROCESS

1.) Has there been an initial decision in the matter? This can be:

- * an existing published wage determination
- * a survey underlying a wage determination
- * a Wage and Hour Division letter setting forth a position on a wage determination matter
- * a conformance (additional classification and rate) ruling

On survey related matters, initial contact, including requests for summaries of surveys, should be with the Wage and Hour National Office because National Office has responsibility for the Davis-Bacon survey program. If the response from this initial contact is not satisfactory, then the process described in 2.) and 3.) should be followed.

With regard to any other matter not yet ripe for the formal process described here, initial contact should be with the Branch of Construction Wage Determinations. Write to:

Branch of Construction Wage Determinations
Wage and Hour Division
U.S. Department of Labor
200 Constitution Avenue, N.W.
Washington, DC 20210

2.) If the answer to the question in 1.) is yes, then an interested party (those affected by the action) can request review and reconsideration from the Wage and Hour Administrator (See 29 CFR Part 1.8 and 29 CFR Part 7). Write to:

Wage and Hour Administrator
U.S. Department of Labor
200 Constitution Avenue, N.W.
Washington, DC 20210

The request should be accompanied by a full statement of the interested party's position and by any information (wage payment data, project description, area practice material, etc.) that the requestor considers relevant to the issue.

3.) If the decision of the Administrator is not favorable, an interested party may appeal directly to the Administrative Review Board (formerly the Wage Appeals Board). Write to:

Administrative Review Board
U.S. Department of Labor
200 Constitution Avenue, N.W.
Washington, DC 20210

4.) All decisions by the Administrative Review Board are final.

END OF GENERAL DECISION"

BID FORMS

SECTION F

BID OPENING

PLACE: _____

DATE: _____

Proposal of _____ (hereinafter called "Bidder") a (circle one) Corporation / Partnership / LLC / Sole Proprietor, organized and existing under the laws of the State of _____, doing business as _____.

TO THE _____ **(hereinafter called "Owner"):**

The Bidder, in compliance with your invitation for bids for the furnishing of materials and/or equipment for the _____ project, having examined the specifications with related documents, hereby proposes to furnish all materials and supplies in accordance with the contract documents, within the time set forth therein, and at the process stated below. These prices are to cover all expenses incurred in performing the work required under the contract documents of which this proposal is a part.

Bidder hereby agrees to commence work under this contract on or before a date to be specified in written "Notice to Proceed" of the Owner and to fully complete the project within _____ consecutive calendar days thereafter as stipulated in the specifications. Bidder further agrees to pay liquidated damages, the sum of \$100.00 for each consecutive calendar day thereafter as hereinafter provided in Paragraph 29 of the General Contract Conditions.

Bidder acknowledges receipt of the following addendum(s):

Bidder agrees to provide all of the _____ Project materials and/or equipment described in the _____ specifications and shown on the plans (if applicable) for the total amount of the bid based on the approximate quantities listed on the following pages. The unit prices specified by the bidder amount to the sum of:

TOTAL BID PER UNIT PRICE PROPOSAL \$ _____

IN WORDS _____

Amounts are to be shown in both words and figures. In case of a discrepancy, amount shown in words will govern.

All unit prices shall include all labor, materials, bailing, shoring, removal, overhead, profit, insurance, etc., to cover providing the materials/equipment called for.

The Bidder understands that the Owner reserves the right to reject any or all bids and to waive any informalities in the bidding process.

The bidder agrees that this bid shall be good and may not be withdrawn for a period of 90 calendar days after the scheduled closing time for receiving bids.

Upon receipt of written notice of the acceptance of this bid, Bidder will execute the formal contract attached within 10 days and deliver a Surety Bond or Bonds as required by Article 12, Section C of the General Contract Conditions. The bid security attached in the sum of \$ _____ (in words) _____ is to become the property of the Owner in the event the contract and bond are not executed within the time above set forth, as liquidated damages for the delay and additional expense to the Owner caused thereby.

RESPECTFULLY SUBMITTED:

BY _____

TITLE _____

BUSINESS NAME AND ADDRESS:

PHONE _____

FED. ID OR SS# _____

SEAL
(If Applicable)

BID GUARANTY AND CONTRACT BOND

(SECTION 153.571 Ohio Revised Code)

KNOW ALL MEN BY THESE PRESENTS, that we, the undersigned _____

(Name and Address)

as Principal and _____

(Name of Surety)

_____ as Surety,

are hereby held and firmly bound unto the _____ as Obligee in the penal sum of the dollar amount of the bid submitted by the Principal to the Obligee on _____ to undertake the project known as _____:

The penal sum referred to herein shall be the dollar amount of the Principal's bid to the Obligee, incorporating any additive or deductive alternate proposals made by the Principal on the date referred to above to the Obligee, which are accepted by the Obligee. In no case shall the penal sum exceed the amount of dollars (_____). (If the above line is left blank, the penal sum will be the full amount of the Principal's bid including alternates, in dollars and cents. A percentage is not acceptable.) For the payment of the penal sum well and truly to be made, we hereby jointly and severally bind ourselves, our heirs, executors, administrators, successors, and assigns.

THE CONDITION OF THE ABOVE OBLIGATION IS SUCH, that whereas the above named Principal has submitted a bid on the above referred to project;

NOW, THEREFORE, if the Obligee accepts the bid of the Principal and the Principal fails to enter into a proper contract in accordance with bid, plans, details, specifications, and bills of material; and in the event the Principal pays to the Obligee the difference not to exceed ten percent of the penalty hereof between the amount specified in the bid, or the costs, in connection with the resubmission, of printing new contract documents, required advertising and printing and mailing notices to prospective bidders, whichever is less, then this obligation shall be null and void, otherwise to remain in full force and effect. If the Obligee accepts the bid of the Principal and the Principal, within ten days after the awarding of the contract, enters into a proper contract in accordance with the bid, plans, details, specifications, and bills of material, which said contract is made a part of this bond the same as though set forth herein; and IF THE SAID Principal shall well and faithfully perform each and every condition of such contract; and indemnify the Obligee against all damage suffered by failure to perform such contract according to the provisions thereof and in accordance with the plans, details, specifications, and bills of material therefore; and shall pay all lawful claims of subcontractors, materialmen, and laborers, for labor performed and materials furnished in the carrying forward, performing, or completing of said contract; we agreeing and assenting that this undertaking shall be for benefit of any materialman or laborer having a just claim, as well as for the Obligee herein; then this obligation shall be void; otherwise the same shall remain in full force and effect; it being expressly understood and agreed that the liability of the Surety for any and all claims hereunder shall in no event exceed the penal amount of this obligation as herein stated.

THE SAID Surety hereby stipulates and agrees that no modifications, omissions, or additions, in or to the terms of said contract or in or to the plans and specifications therefore shall in any way affect the obligations of said Surety on this bond, and it does hereby waive notice of any such modifications, omissions or additions to the term of the contract or to the work or to the specifications.

SIGNED AND SEALED This _____ day of _____, _____.

Principal

By: _____

Title: _____

Surety

By: _____
Attorney-in-Fact

Surety Company Address:

Surety Agent's Name and Address:

**AFFIDAVIT OF CONTRACTOR OR SUPPLIER OF NON-DELINQUENCY OF
PERSONAL PROPERTY TAXES**

O.R.C. 5919.042

STATE OF OHIO:

SS:

TO: _____

The undersigned, being first duly sworn, having been awarded a contract by you for _____ hereby states that we are not charged at the time the proposal was submitted with any delinquent personal property taxes on the general tax list of personal property of any county in which you as a taxing district have territory and that we were not charged with delinquent personal property taxes on any such tax list.

In consideration of the award of the above contract, the above statement is incorporated in said contract as a covenant of the undersigned.

Subscribed and sworn to before me this ____ day of _____, ____.

Notary Public

My Commission Expires

SEAL

NON-COLLUSION AFFIDAVIT

State of Ohio

County of _____

BID Identification: _____

CONTRACTOR: _____

being duly sworn, deposed and says that he is _____ (Sole owner, a partner, president, secretary, etc.) of _____, the party making the foregoing BID; that such BID is not made in the interest of or on behalf of any undisclosed person, partnership, company, association, organization, or corporation; that such BID is genuine and not collusive or sham; that said BIDDER has not directly or indirectly induced or solicited any other BIDDER to put in a fake or sham BID and has not directly or indirectly colluded, conspired, connived, or agreed with any BIDDER or anyone else to put in a sham BID, or that any one shall refrain from bidding; that said BIDDER has not in any manner directly or indirectly, sought by agreement, communication or conference with anyone to fix the BID price of said BIDDER or of any other BIDDER, or to fix any overhead, profit, or cost element of such BID price, or of that of any other BIDDER, or to secure any advantage against the OWNER awarding the contract or anyone interested in the proposed contract; that all statements contained in such BID are true; and, further, that said BIDDER has not, directly or indirectly, submitted his BID price or any breakdown thereof, or the contents thereof, or divulged information or data relative thereto, or paid and will not pay any fee in connection therewith, to any corporation, partnership, company, association, organization, BID depository, or to any member or agent thereof, or to any other individual except to such person or persons as have a partnership or other financial interest with said BIDDER in his general business.

Signed:

Subscribed and sworn to before me this ____ day of _____, _____.

Notary Public

My Commission Expires

SEAL

**CERTIFICATION REGARDING
DEBARMENT, SUSPENSION, AND OTHER RESPONSIBILITY MATTERS
PRIMARY COVERED TRANSACTIONS**

This certification is required by the regulations implementing Executive Order 12549, Debarment and Suspension, 34 CFR Part 85, Section 85.510, Participant's responsibilities. The regulations were published as Part VII of the May 26, 1988 Federal Register (pages 19160 - 19211). Copies of the regulation may be obtained by contacting the U.S. Department of Education, Grants and Contracts Service, 400 Maryland Avenue, S.W. (Room 3633 GSA Regional Office Building No. 3), Washington, DC. 20202-4725, telephone (202) 732-2505.

- (1) The prospective primary participant certifies to the best of its knowledge and belief, that it and its principals:
- (a) Are not presently debarred, suspended, proposed for debarment, declared ineligible, or voluntarily excluded from covered transactions by any Federal department or agency;
 - (b) Have not within a three-year period preceding this proposal been convicted of or had a civil judgment rendered against them for commission of fraud or a criminal offense in connection with obtaining, attempting to obtain, or performing a public (Federal, State, or Local) transaction or contract under a public transaction; violation of Federal or State antitrust statutes or commission of embezzlement, theft, forgery, bribery, falsification or destruction of records, making false statements, or receiving stolen property;
 - (c) Are not presently indicted for or otherwise criminally or civilly charged by a governmental entity (Federal, State, or Local) with commission of any of the offenses enumerated in paragraph (1)(b) of this certification; and
 - (d) Have not within a three-year period preceding this application/proposal had one or more public transactions (Federal, State, or Local) terminated for cause or default.
- (2) Where the prospective primary participant is unable to certify to any of the statements in this certification, such prospective participant shall attach an explanation to this proposal.

Organization Name

PR/Award Number or Project Name

Name and Title of Authorized Representative

Signature
ED Form GCS-008 (REV.12/88)

Date

**AFFIDAVIT IN COMPLIANCE WITH SECTION 3517.13
OF THE OHIO REVISED CODE**

STATE OF OHIO

COUNTY OF _____, SS:

Personally appeared before me the undersigned, as an individual or as a representative of

_____ for a contract for _____
(Name of Entity) (Type of Product or Service)

to be let by the County of _____, who, being duly cautioned and sworn, makes the following statement with respect to prohibited activities constituting a conflict of interest or other violations under Ohio Revised Code Section 3517.13, and further states that the undersigned has the authority to make the following representation on behalf of himself or of the business entity:

1. That none of the following has individually made within the two previous calendar years and that, if awarded a contract for the purchase of goods or services in excess of \$500.00, none of the following individually will make, beginning on the date the contract is awarded and extending until one year following the conclusion of the contract, as an individual, one or more campaign contributions totaling in excess of \$1,000.00, to any member of the _____ County Board of Commissioners or their individual campaign committees:
 - a. myself;
 - b. any partner or owner or shareholder of the partnership (if applicable);
 - c. any owner of more than 20% of the corporation or business trust (if applicable);
 - d. each spouse of any person identified in (a) through (c) of this section;
 - e. each child seven years of age to seventeen years of age of any person identified in divisions (a) through (c) of this section (only applicable to contributions made on or after January 1, 2007).

2. That none of the following have collectively made since January 1, 2007 and that, if awarded a contract for the purchase of goods or services in excess of \$500.00, none of the following collectively will make, beginning on the date the contract is awarded and extending until one year following the conclusion of the contract, one or more campaign contributions totaling in excess of \$2,000.00, to any member of the _____ County Board of Commissioners or their individual campaign committees:
 - a. myself;
 - b. nay partner or owner or shareholder of the partnership (if applicable);
 - c. any owner of more than 20% of the corporation or business trust (if applicable);
 - d. each spouse of any person identified in (a) through (c) of this section;
 - e. each child seven years of age to seventeen years of age of any person identified in divisions (a) through (c) of this section (only applicable to contributions made on or after January 1, 2007).

Signature _____

Title: _____

Sworn to before me and subscribed in my presence this _____ day of _____, 20_____.

Notary Public _____

My Commission Expires: _____

SEAL

ADDITIONAL CERTIFICATIONS

Project Name: _____

Grant Number: _____

I certify that my company has the *facilities* to complete this job.

I certify that my company has the *labor force* to complete this job.

I certify that my company has the *equipment* to complete this job.

I certify that my company has the *administrative capacity* to complete this job.

I certify that my company has the *knowledge* to complete this job.

I certify that my company maintains a *drug free workplace*.

Name and Title of Authorized Representative

Signature & Date

BONDING AND INSURANCE REQUIREMENTS

A state or local unit of government receiving a grant from the Federal government which requires contracting for construction of facility improvement shall follow its own requirement relating to bid guarantees, performance bonds, and payment bonds, except for contracts or subcontracts exceeding \$100,000.00. For contracts or subcontracts exceeding \$100,000.00, the Federal agency may accept the bonding policy requirement of the grantee provided the Federal agency has made a determination that the Government's interest in adequately protected. If such a determination has not been made, the minimum requirements shall be as follows:

- A. A bid guarantee from each bidder equivalent to ten percent of the bid price. The "bid guarantee" shall consist of a firm commitment such as a bid bond, certified check, or other negotiable instrument accompanying a bid as assurance that the bidder will, upon acceptance of his/her bid, execute such contractual documents as may be required within the time specified.

- B. A performance bond on the part of the contractor for 100 percent of the contract price. A "performance bond" is one executed in connection with a contract to secure fulfillment of all the contractor's obligations under such contract.

- C. A payment bond on the part of the contractor for 100 percent of the contract price. A "payment bond" is one executed in connection with a contract to assure payment as required by law of all persons supplying labor and material in the execution of the work provided for in the contract.

EXPERIENCE STATEMENT OF BIDDER

The BIDDER/CONTRACTOR is required to state in detail, in the space provided below, what work of character similar to that included in this proposed Contract Documents it has done, to give reference and such other detailed information as it will enable the OWNER to determine responsibility including experience, skill and financial standing.

PROJECT NAME: _____ CONTACT: _____
ADDRESS: _____
PHONE: _____ FAX: _____
EMAIL: _____ DATE OF PROJECT: _____
DESCRIPTION OF WORK: _____

PROJECT NAME: _____ CONTACT: _____
ADDRESS: _____
PHONE: _____ FAX: _____
EMAIL: _____ DATE OF PROJECT: _____
DESCRIPTION OF WORK: _____

PROJECT NAME: _____ CONTACT: _____
ADDRESS: _____
PHONE: _____ FAX: _____
EMAIL: _____ DATE OF PROJECT: _____
DESCRIPTION OF WORK: _____

PROJECT NAME: _____ CONTACT: _____
ADDRESS: _____
PHONE: _____ FAX: _____
EMAIL: _____ DATE OF PROJECT: _____
DESCRIPTION OF WORK: _____

Request for Taxpayer Identification Number and Certification

**Give Form to the
 requester. Do not
 send to the IRS.**

Print or type See Specific Instructions on page 2.	1 Name (as shown on your income tax return). Name is required on this line; do not leave this line blank.	
	2 Business name/disregarded entity name, if different from above	
	3 Check appropriate box for federal tax classification; check only one of the following seven boxes: <input type="checkbox"/> Individual/sole proprietor or single-member LLC <input type="checkbox"/> C Corporation <input type="checkbox"/> S Corporation <input type="checkbox"/> Partnership <input type="checkbox"/> Trust/estate <input type="checkbox"/> Limited liability company. Enter the tax classification (C=C corporation, S=S corporation, P=partnership) ▶ _____ Note. For a single-member LLC that is disregarded, do not check LLC; check the appropriate box in the line above for the tax classification of the single-member owner. <input type="checkbox"/> Other (see instructions) ▶ _____	4 Exemptions (codes apply only to certain entities, not individuals; see instructions on page 3): Exempt payee code (if any) _____ Exemption from FATCA reporting code (if any) _____ <i>(Applies to accounts maintained outside the U.S.)</i>
	5 Address (number, street, and apt. or suite no.)	Requester's name and address (optional)
	6 City, state, and ZIP code	
	7 List account number(s) here (optional)	

Part I Taxpayer Identification Number (TIN)

Enter your TIN in the appropriate box. The TIN provided must match the name given on line 1 to avoid backup withholding. For individuals, this is generally your social security number (SSN). However, for a resident alien, sole proprietor, or disregarded entity, see the Part I instructions on page 3. For other entities, it is your employer identification number (EIN). If you do not have a number, see *How to get a TIN* on page 3.

Note. If the account is in more than one name, see the instructions for line 1 and the chart on page 4 for guidelines on whose number to enter.

Social security number									
				-			-		
or									
Employer identification number									
				-					

Part II Certification

Under penalties of perjury, I certify that:

1. The number shown on this form is my correct taxpayer identification number (or I am waiting for a number to be issued to me); and
2. I am not subject to backup withholding because: (a) I am exempt from backup withholding, or (b) I have not been notified by the Internal Revenue Service (IRS) that I am subject to backup withholding as a result of a failure to report all interest or dividends, or (c) the IRS has notified me that I am no longer subject to backup withholding; and
3. I am a U.S. citizen or other U.S. person (defined below); and
4. The FATCA code(s) entered on this form (if any) indicating that I am exempt from FATCA reporting is correct.

Certification instructions. You must cross out item 2 above if you have been notified by the IRS that you are currently subject to backup withholding because you have failed to report all interest and dividends on your tax return. For real estate transactions, item 2 does not apply. For mortgage interest paid, acquisition or abandonment of secured property, cancellation of debt, contributions to an individual retirement arrangement (IRA), and generally, payments other than interest and dividends, you are not required to sign the certification, but you must provide your correct TIN. See the instructions on page 3.

Sign Here	Signature of U.S. person ▶	Date ▶
------------------	----------------------------	--------

General Instructions

Section references are to the Internal Revenue Code unless otherwise noted.

Future developments. Information about developments affecting Form W-9 (such as legislation enacted after we release it) is at www.irs.gov/fw9.

Purpose of Form

An individual or entity (Form W-9 requester) who is required to file an information return with the IRS must obtain your correct taxpayer identification number (TIN) which may be your social security number (SSN), individual taxpayer identification number (ITIN), adoption taxpayer identification number (ATIN), or employer identification number (EIN), to report on an information return the amount paid to you, or other amount reportable on an information return. Examples of information returns include, but are not limited to, the following:

- Form 1099-INT (interest earned or paid)
- Form 1099-DIV (dividends, including those from stocks or mutual funds)
- Form 1099-MISC (various types of income, prizes, awards, or gross proceeds)
- Form 1099-B (stock or mutual fund sales and certain other transactions by brokers)
- Form 1099-S (proceeds from real estate transactions)
- Form 1099-K (merchant card and third party network transactions)

- Form 1098 (home mortgage interest), 1098-E (student loan interest), 1098-T (tuition)
- Form 1099-C (canceled debt)
- Form 1099-A (acquisition or abandonment of secured property)

Use Form W-9 only if you are a U.S. person (including a resident alien), to provide your correct TIN.

If you do not return Form W-9 to the requester with a TIN, you might be subject to backup withholding. See What is backup withholding? on page 2.

By signing the filled-out form, you:

1. Certify that the TIN you are giving is correct (or you are waiting for a number to be issued),
2. Certify that you are not subject to backup withholding, or
3. Claim exemption from backup withholding if you are a U.S. exempt payee. If applicable, you are also certifying that as a U.S. person, your allocable share of any partnership income from a U.S. trade or business is not subject to the withholding tax on foreign partners' share of effectively connected income, and
4. Certify that FATCA code(s) entered on this form (if any) indicating that you are exempt from the FATCA reporting, is correct. See *What is FATCA reporting?* on page 2 for further information.

Note. If you are a U.S. person and a requester gives you a form other than Form W-9 to request your TIN, you must use the requester's form if it is substantially similar to this Form W-9.

Definition of a U.S. person. For federal tax purposes, you are considered a U.S. person if you are:

- An individual who is a U.S. citizen or U.S. resident alien;
- A partnership, corporation, company, or association created or organized in the United States or under the laws of the United States;
- An estate (other than a foreign estate); or
- A domestic trust (as defined in Regulations section 301.7701-7).

Special rules for partnerships. Partnerships that conduct a trade or business in the United States are generally required to pay a withholding tax under section 1446 on any foreign partners' share of effectively connected taxable income from such business. Further, in certain cases where a Form W-9 has not been received, the rules under section 1446 require a partnership to presume that a partner is a foreign person, and pay the section 1446 withholding tax. Therefore, if you are a U.S. person that is a partner in a partnership conducting a trade or business in the United States, provide Form W-9 to the partnership to establish your U.S. status and avoid section 1446 withholding on your share of partnership income.

In the cases below, the following persons must give Form W-9 to the partnership for purposes of establishing its U.S. status and avoiding withholding on its allocable share of net income from the partnership conducting a trade or business in the United States:

- In the case of a disregarded entity with a U.S. owner, the U.S. owner of the disregarded entity and not the entity;
- In the case of a grantor trust with a U.S. grantor or other U.S. owner, generally, the U.S. grantor or other U.S. owner of the grantor trust and not the trust; and
- In the case of a U.S. trust (other than a grantor trust), the U.S. trust (other than a grantor trust) and not the beneficiaries of the trust.

Foreign person. If you are a foreign person or the U.S. branch of a foreign bank that has elected to be treated as a U.S. person, do not use Form W-9. Instead, use the appropriate Form W-8 or Form 8233 (see Publication 515, Withholding of Tax on Nonresident Aliens and Foreign Entities).

Nonresident alien who becomes a resident alien. Generally, only a nonresident alien individual may use the terms of a tax treaty to reduce or eliminate U.S. tax on certain types of income. However, most tax treaties contain a provision known as a "saving clause." Exceptions specified in the saving clause may permit an exemption from tax to continue for certain types of income even after the payee has otherwise become a U.S. resident alien for tax purposes.

If you are a U.S. resident alien who is relying on an exception contained in the saving clause of a tax treaty to claim an exemption from U.S. tax on certain types of income, you must attach a statement to Form W-9 that specifies the following five items:

1. The treaty country. Generally, this must be the same treaty under which you claimed exemption from tax as a nonresident alien.
2. The treaty article addressing the income.
3. The article number (or location) in the tax treaty that contains the saving clause and its exceptions.
4. The type and amount of income that qualifies for the exemption from tax.
5. Sufficient facts to justify the exemption from tax under the terms of the treaty article.

Example. Article 20 of the U.S.-China income tax treaty allows an exemption from tax for scholarship income received by a Chinese student temporarily present in the United States. Under U.S. law, this student will become a resident alien for tax purposes if his or her stay in the United States exceeds 5 calendar years. However, paragraph 2 of the first Protocol to the U.S.-China treaty (dated April 30, 1984) allows the provisions of Article 20 to continue to apply even after the Chinese student becomes a resident alien of the United States. A Chinese student who qualifies for this exception (under paragraph 2 of the first protocol) and is relying on this exception to claim an exemption from tax on his or her scholarship or fellowship income would attach to Form W-9 a statement that includes the information described above to support that exemption.

If you are a nonresident alien or a foreign entity, give the requester the appropriate completed Form W-8 or Form 8233.

Backup Withholding

What is backup withholding? Persons making certain payments to you must under certain conditions withhold and pay to the IRS 28% of such payments. This is called "backup withholding." Payments that may be subject to backup withholding include interest, tax-exempt interest, dividends, broker and barter exchange transactions, rents, royalties, nonemployee pay, payments made in settlement of payment card and third party network transactions, and certain payments from fishing boat operators. Real estate transactions are not subject to backup withholding.

You will not be subject to backup withholding on payments you receive if you give the requester your correct TIN, make the proper certifications, and report all your taxable interest and dividends on your tax return.

Payments you receive will be subject to backup withholding if:

1. You do not furnish your TIN to the requester,
2. You do not certify your TIN when required (see the Part II instructions on page 3 for details),

3. The IRS tells the requester that you furnished an incorrect TIN,

4. The IRS tells you that you are subject to backup withholding because you did not report all your interest and dividends on your tax return (for reportable interest and dividends only), or

5. You do not certify to the requester that you are not subject to backup withholding under 4 above (for reportable interest and dividend accounts opened after 1983 only).

Certain payees and payments are exempt from backup withholding. See *Exempt payee code* on page 3 and the separate Instructions for the Requester of Form W-9 for more information.

Also see *Special rules for partnerships* above.

What is FATCA reporting?

The Foreign Account Tax Compliance Act (FATCA) requires a participating foreign financial institution to report all United States account holders that are specified United States persons. Certain payees are exempt from FATCA reporting. See *Exemption from FATCA reporting code* on page 3 and the Instructions for the Requester of Form W-9 for more information.

Updating Your Information

You must provide updated information to any person to whom you claimed to be an exempt payee if you are no longer an exempt payee and anticipate receiving reportable payments in the future from this person. For example, you may need to provide updated information if you are a C corporation that elects to be an S corporation, or if you no longer are tax exempt. In addition, you must furnish a new Form W-9 if the name or TIN changes for the account; for example, if the grantor of a grantor trust dies.

Penalties

Failure to furnish TIN. If you fail to furnish your correct TIN to a requester, you are subject to a penalty of \$50 for each such failure unless your failure is due to reasonable cause and not to willful neglect.

Civil penalty for false information with respect to withholding. If you make a false statement with no reasonable basis that results in no backup withholding, you are subject to a \$500 penalty.

Criminal penalty for falsifying information. Willfully falsifying certifications or affirmations may subject you to criminal penalties including fines and/or imprisonment.

Misuse of TINs. If the requester discloses or uses TINs in violation of federal law, the requester may be subject to civil and criminal penalties.

Specific Instructions

Line 1

You must enter one of the following on this line; **do not** leave this line blank. The name should match the name on your tax return.

If this Form W-9 is for a joint account, list first, and then circle, the name of the person or entity whose number you entered in Part I of Form W-9.

a. **Individual.** Generally, enter the name shown on your tax return. If you have changed your last name without informing the Social Security Administration (SSA) of the name change, enter your first name, the last name as shown on your social security card, and your new last name.

Note. ITIN applicant: Enter your individual name as it was entered on your Form W-7 application, line 1a. This should also be the same as the name you entered on the Form 1040/1040A/1040EZ you filed with your application.

b. **Sole proprietor or single-member LLC.** Enter your individual name as shown on your 1040/1040A/1040EZ on line 1. You may enter your business, trade, or "doing business as" (DBA) name on line 2.

c. **Partnership, LLC that is not a single-member LLC, C Corporation, or S Corporation.** Enter the entity's name as shown on the entity's tax return on line 1 and any business, trade, or DBA name on line 2.

d. **Other entities.** Enter your name as shown on required U.S. federal tax documents on line 1. This name should match the name shown on the charter or other legal document creating the entity. You may enter any business, trade, or DBA name on line 2.

e. **Disregarded entity.** For U.S. federal tax purposes, an entity that is disregarded as an entity separate from its owner is treated as a "disregarded entity." See Regulations section 301.7701-2(c)(2)(iii). Enter the owner's name on line 1. The name of the entity entered on line 1 should never be a disregarded entity. The name on line 1 should be the name shown on the income tax return on which the income should be reported. For example, if a foreign LLC that is treated as a disregarded entity for U.S. federal tax purposes has a single owner that is a U.S. person, the U.S. owner's name is required to be provided on line 1. If the direct owner of the entity is also a disregarded entity, enter the first owner that is not disregarded for federal tax purposes. Enter the disregarded entity's name on line 2, "Business name/disregarded entity name." If the owner of the disregarded entity is a foreign person, the owner must complete an appropriate Form W-8 instead of a Form W-9. This is the case even if the foreign person has a U.S. TIN.

Line 2

If you have a business name, trade name, DBA name, or disregarded entity name, you may enter it on line 2.

Line 3

Check the appropriate box in line 3 for the U.S. federal tax classification of the person whose name is entered on line 1. Check only one box in line 3.

Limited Liability Company (LLC). If the name on line 1 is an LLC treated as a partnership for U.S. federal tax purposes, check the "Limited Liability Company" box and enter "P" in the space provided. If the LLC has filed Form 8832 or 2553 to be taxed as a corporation, check the "Limited Liability Company" box and in the space provided enter "C" for C corporation or "S" for S corporation. If it is a single-member LLC that is a disregarded entity, do not check the "Limited Liability Company" box; instead check the first box in line 3 "Individual/sole proprietor or single-member LLC."

Line 4, Exemptions

If you are exempt from backup withholding and/or FATCA reporting, enter in the appropriate space in line 4 any code(s) that may apply to you.

Exempt payee code.

- Generally, individuals (including sole proprietors) are not exempt from backup withholding.
- Except as provided below, corporations are exempt from backup withholding for certain payments, including interest and dividends.
- Corporations are not exempt from backup withholding for payments made in settlement of payment card or third party network transactions.
- Corporations are not exempt from backup withholding with respect to attorneys' fees or gross proceeds paid to attorneys, and corporations that provide medical or health care services are not exempt with respect to payments reportable on Form 1099-MISC.

The following codes identify payees that are exempt from backup withholding. Enter the appropriate code in the space in line 4.

- 1—An organization exempt from tax under section 501(a), any IRA, or a custodial account under section 403(b)(7) if the account satisfies the requirements of section 401(f)(2)
- 2—The United States or any of its agencies or instrumentalities
- 3—A state, the District of Columbia, a U.S. commonwealth or possession, or any of their political subdivisions or instrumentalities
- 4—A foreign government or any of its political subdivisions, agencies, or instrumentalities
- 5—A corporation
- 6—A dealer in securities or commodities required to register in the United States, the District of Columbia, or a U.S. commonwealth or possession
- 7—A futures commission merchant registered with the Commodity Futures Trading Commission
- 8—A real estate investment trust
- 9—An entity registered at all times during the tax year under the Investment Company Act of 1940
- 10—A common trust fund operated by a bank under section 584(a)
- 11—A financial institution
- 12—A middleman known in the investment community as a nominee or custodian
- 13—A trust exempt from tax under section 664 or described in section 4947

The following chart shows types of payments that may be exempt from backup withholding. The chart applies to the exempt payees listed above, 1 through 13.

IF the payment is for . . .	THEN the payment is exempt for . . .
Interest and dividend payments	All exempt payees except for 7
Broker transactions	Exempt payees 1 through 4 and 6 through 11 and all C corporations. S corporations must not enter an exempt payee code because they are exempt only for sales of noncovered securities acquired prior to 2012.
Barter exchange transactions and patronage dividends	Exempt payees 1 through 4
Payments over \$600 required to be reported and direct sales over \$5,000 ¹	Generally, exempt payees 1 through 5 ²
Payments made in settlement of payment card or third party network transactions	Exempt payees 1 through 4

¹ See Form 1099-MISC, Miscellaneous Income, and its instructions.

² However, the following payments made to a corporation and reportable on Form 1099-MISC are not exempt from backup withholding: medical and health care payments, attorneys' fees, gross proceeds paid to an attorney reportable under section 6045(f), and payments for services paid by a federal executive agency.

Exemption from FATCA reporting code. The following codes identify payees that are exempt from reporting under FATCA. These codes apply to persons submitting this form for accounts maintained outside of the United States by certain foreign financial institutions. Therefore, if you are only submitting this form for an account you hold in the United States, you may leave this field blank. Consult with the person requesting this form if you are uncertain if the financial institution is subject to these requirements. A requester may indicate that a code is not required by providing you with a Form W-9 with "Not Applicable" (or any similar indication) written or printed on the line for a FATCA exemption code.

A—An organization exempt from tax under section 501(a) or any individual retirement plan as defined in section 7701(a)(37)

B—The United States or any of its agencies or instrumentalities

C—A state, the District of Columbia, a U.S. commonwealth or possession, or any of their political subdivisions or instrumentalities

D—A corporation the stock of which is regularly traded on one or more established securities markets, as described in Regulations section 1.1472-1(c)(1)(i)

E—A corporation that is a member of the same expanded affiliated group as a corporation described in Regulations section 1.1472-1(c)(1)(i)

F—A dealer in securities, commodities, or derivative financial instruments (including notional principal contracts, futures, forwards, and options) that is registered as such under the laws of the United States or any state

G—A real estate investment trust

H—A regulated investment company as defined in section 851 or an entity registered at all times during the tax year under the Investment Company Act of 1940

I—A common trust fund as defined in section 584(a)

J—A bank as defined in section 581

K—A broker

L—A trust exempt from tax under section 664 or described in section 4947(a)(1)

M—A tax exempt trust under a section 403(b) plan or section 457(g) plan

Note. You may wish to consult with the financial institution requesting this form to determine whether the FATCA code and/or exempt payee code should be completed.

Line 5

Enter your address (number, street, and apartment or suite number). This is where the requester of this Form W-9 will mail your information returns.

Line 6

Enter your city, state, and ZIP code.

Part I. Taxpayer Identification Number (TIN)

Enter your TIN in the appropriate box. If you are a resident alien and you do not have and are not eligible to get an SSN, your TIN is your IRS individual taxpayer identification number (ITIN). Enter it in the social security number box. If you do not have an ITIN, see *How to get a TIN* below.

If you are a sole proprietor and you have an EIN, you may enter either your SSN or EIN. However, the IRS prefers that you use your SSN.

If you are a single-member LLC that is disregarded as an entity separate from its owner (see *Limited Liability Company (LLC)* on this page), enter the owner's SSN (or EIN, if the owner has one). Do not enter the disregarded entity's EIN. If the LLC is classified as a corporation or partnership, enter the entity's EIN.

Note. See the chart on page 4 for further clarification of name and TIN combinations.

How to get a TIN. If you do not have a TIN, apply for one immediately. To apply for an SSN, get Form SS-5, Application for a Social Security Card, from your local SSA office or get this form online at www.ssa.gov. You may also get this form by calling 1-800-772-1213. Use Form W-7, Application for IRS Individual Taxpayer Identification Number, to apply for an ITIN, or Form SS-4, Application for Employer Identification Number, to apply for an EIN. You can apply for an EIN online by accessing the IRS website at www.irs.gov/businesses and clicking on Employer Identification Number (EIN) under Starting a Business. You can get Forms W-7 and SS-4 from the IRS by visiting IRS.gov or by calling 1-800-TAX-FORM (1-800-829-3676).

If you are asked to complete Form W-9 but do not have a TIN, apply for a TIN and write "Applied For" in the space for the TIN, sign and date the form, and give it to the requester. For interest and dividend payments, and certain payments made with respect to readily tradable instruments, generally you will have 60 days to get a TIN and give it to the requester before you are subject to backup withholding on payments. The 60-day rule does not apply to other types of payments. You will be subject to backup withholding on all such payments until you provide your TIN to the requester.

Note. Entering "Applied For" means that you have already applied for a TIN or that you intend to apply for one soon.

Caution: A disregarded U.S. entity that has a foreign owner must use the appropriate Form W-8.

Part II. Certification

To establish to the withholding agent that you are a U.S. person, or resident alien, sign Form W-9. You may be requested to sign by the withholding agent even if items 1, 4, or 5 below indicate otherwise.

For a joint account, only the person whose TIN is shown in Part I should sign (when required). In the case of a disregarded entity, the person identified on line 1 must sign. Exempt payees, see *Exempt payee code* earlier.

Signature requirements. Complete the certification as indicated in items 1 through 5 below.

- 1. Interest, dividend, and barter exchange accounts opened before 1984 and broker accounts considered active during 1983.** You must give your correct TIN, but you do not have to sign the certification.
- 2. Interest, dividend, broker, and barter exchange accounts opened after 1983 and broker accounts considered inactive during 1983.** You must sign the certification or backup withholding will apply. If you are subject to backup withholding and you are merely providing your correct TIN to the requester, you must cross out item 2 in the certification before signing the form.
- 3. Real estate transactions.** You must sign the certification. You may cross out item 2 of the certification.
- 4. Other payments.** You must give your correct TIN, but you do not have to sign the certification unless you have been notified that you have previously given an incorrect TIN. "Other payments" include payments made in the course of the requester's trade or business for rents, royalties, goods (other than bills for merchandise), medical and health care services (including payments to corporations), payments to a nonemployee for services, payments made in settlement of payment card and third party network transactions, payments to certain fishing boat crew members and fishermen, and gross proceeds paid to attorneys (including payments to corporations).
- 5. Mortgage interest paid by you, acquisition or abandonment of secured property, cancellation of debt, qualified tuition program payments (under section 529), IRA, Coverdell ESA, Archer MSA or HSA contributions or distributions, and pension distributions.** You must give your correct TIN, but you do not have to sign the certification.

What Name and Number To Give the Requester

For this type of account:	Give name and SSN of:
1. Individual	The individual
2. Two or more individuals (joint account)	The actual owner of the account or, if combined funds, the first individual on the account ¹
3. Custodian account of a minor (Uniform Gift to Minors Act)	The minor ²
4. a. The usual revocable savings trust (grantor is also trustee) b. So-called trust account that is not a legal or valid trust under state law	The grantor-trustee ¹ The actual owner ¹
5. Sole proprietorship or disregarded entity owned by an individual	The owner ³
6. Grantor trust filing under Optional Form 1099 Filing Method 1 (see Regulations section 1.671-4(b)(2)(i)(A))	The grantor*
For this type of account:	Give name and EIN of:
7. Disregarded entity not owned by an individual	The owner
8. A valid trust, estate, or pension trust	Legal entity ⁴
9. Corporation or LLC electing corporate status on Form 8832 or Form 2553	The corporation
10. Association, club, religious, charitable, educational, or other tax-exempt organization	The organization
11. Partnership or multi-member LLC	The partnership
12. A broker or registered nominee	The broker or nominee
13. Account with the Department of Agriculture in the name of a public entity (such as a state or local government, school district, or prison) that receives agricultural program payments	The public entity
14. Grantor trust filing under the Form 1041 Filing Method or the Optional Form 1099 Filing Method 2 (see Regulations section 1.671-4(b)(2)(i)(B))	The trust

¹ List first and circle the name of the person whose number you furnish. If only one person on a joint account has an SSN, that person's number must be furnished.

² Circle the minor's name and furnish the minor's SSN.

³ You must show your individual name and you may also enter your business or DBA name on the "Business name/disregarded entity" name line. You may use either your SSN or EIN (if you have one), but the IRS encourages you to use your SSN.

⁴ List first and circle the name of the trust, estate, or pension trust. (Do not furnish the TIN of the personal representative or trustee unless the legal entity itself is not designated in the account title.) Also see *Special rules for partnerships* on page 2.

*Note. Grantor also must provide a Form W-9 to trustee of trust.

Note. If no name is circled when more than one name is listed, the number will be considered to be that of the first name listed.

Secure Your Tax Records from Identity Theft

Identity theft occurs when someone uses your personal information such as your name, SSN, or other identifying information, without your permission, to commit fraud or other crimes. An identity thief may use your SSN to get a job or may file a tax return using your SSN to receive a refund.

To reduce your risk:

- Protect your SSN,
- Ensure your employer is protecting your SSN, and
- Be careful when choosing a tax preparer.

If your tax records are affected by identity theft and you receive a notice from the IRS, respond right away to the name and phone number printed on the IRS notice or letter.

If your tax records are not currently affected by identity theft but you think you are at risk due to a lost or stolen purse or wallet, questionable credit card activity or credit report, contact the IRS Identity Theft Hotline at 1-800-908-4490 or submit Form 14039.

For more information, see Publication 4535, Identity Theft Prevention and Victim Assistance.

Victims of identity theft who are experiencing economic harm or a system problem, or are seeking help in resolving tax problems that have not been resolved through normal channels, may be eligible for Taxpayer Advocate Service (TAS) assistance. You can reach TAS by calling the TAS toll-free case intake line at 1-877-777-4778 or TTY/TDD 1-800-829-4059.

Protect yourself from suspicious emails or phishing schemes. Phishing is the creation and use of email and websites designed to mimic legitimate business emails and websites. The most common act is sending an email to a user falsely claiming to be an established legitimate enterprise in an attempt to scam the user into surrendering private information that will be used for identity theft.

The IRS does not initiate contacts with taxpayers via emails. Also, the IRS does not request personal detailed information through email or ask taxpayers for the PIN numbers, passwords, or similar secret access information for their credit card, bank, or other financial accounts.

If you receive an unsolicited email claiming to be from the IRS, forward this message to phishing@irs.gov. You may also report misuse of the IRS name, logo, or other IRS property to the Treasury Inspector General for Tax Administration (TIGTA) at 1-800-366-4484. You can forward suspicious emails to the Federal Trade Commission at: spam@uce.gov or contact them at www.ftc.gov/idtheft or 1-877-IDTHEFT (1-877-438-4338).

Visit IRS.gov to learn more about identity theft and how to reduce your risk.

Privacy Act Notice

Section 6109 of the Internal Revenue Code requires you to provide your correct TIN to persons (including federal agencies) who are required to file information returns with the IRS to report interest, dividends, or certain other income paid to you; mortgage interest you paid; the acquisition or abandonment of secured property; the cancellation of debt; or contributions you made to an IRA, Archer MSA, or HSA. The person collecting this form uses the information on the form to file information returns with the IRS, reporting the above information. Routine uses of this information include giving it to the Department of Justice for civil and criminal litigation and to cities, states, the District of Columbia, and U.S. commonwealths and possessions for use in administering their laws. The information also may be disclosed to other countries under a treaty, to federal and state agencies to enforce civil and criminal laws, or to federal law enforcement and intelligence agencies to combat terrorism. You must provide your TIN whether or not you are required to file a tax return. Under section 3406, payers must generally withhold a percentage of taxable interest, dividend, and certain other payments to a payee who does not give a TIN to the payer. Certain penalties may also apply for providing false or fraudulent information.

TABLE OF CONTENTS

SECTION G: AGREEMENT FORMS

- Certifications - Performance and Payment Bond
- Notice of Award
- Contract
- Notice to Proceed
- Notice of Commencement
- Change Order
- Certificate of Owner's Attorney
- Certificate of Owner's Financial Officer
- Conflict of Interest
 - Interest of Contractor and Employees
 - Records and Audits
 - Federal or State Officials Not to Benefit
- Special Conditions Pertaining to Hazards Safety Standards and Accident Prevention
 - Lead-Based Paint Hazards
 - Use of Explosives
 - Danger Signals and Safety Devices
- Special Equal Opportunity Provisions
 - A. Activities and Contracts not Subject to Executive Order 11246, as Amended
 - B. Executive Order 11246 (Contracts/Subcontracts over \$10,000)
 - Goals for minority and Female Participation
 - C. Notice of Requirement for Affirmative Action to Ensure Equal Employment Opportunity
 - D. Standard Federal EEO Construction Contract Specifications
 - E. Certification of Non-Segregated Facilities (over \$10,000)
 - F. Civil Rights Act of 1964
 - G. Section 109 of the Housing and Community Development Act of 1974
 - H. "SECTION 3" Compliance in the provision of Training, Employment and Business Opportunities
- Contractor, Section 3 Plan Format Signature Page

- Table A – Proposed Subcontracts Breakdown
- Table B – Estimated Project Workforce Breakdown
- Certification of Bidder Regarding Equal Employment Opportunity
- Certification of Subcontractor Regarding Equal Employment Opportunity
- Certification of Bidder Regarding Section 3 – Segregated Facilities
- Certification of Proposed Subcontractor Section 3 – Segregated Facilities
- Certification of Compliance with Air and Water Acts (Applicable to contracts exceeding \$10,000)

SECTION H: FEDERAL LABOR STANDARDS PROVISIONS

- Certification of Compliance with Federal Labor Standards Provisions - Reprint of HUD-4010 (pp. 1 - 8) Revised July 2003
- Contractor's Certification: Concerning Labor Standards and Prevailing Wage Requirements
- Subcontractor's Certification: Concerning Labor Standards and Prevailing Wage Requirements

READ BEFORE COMPLETING YOUR DMA FORM

Forms not conforming to the specifications listed below or not submitted to the appropriate agency or office will not be processed.

- To complete this form, you will need a copy of the Terrorist Exclusion List for reference. The Terrorist Exclusion List can be found on the Ohio Homeland Security Web site at the following address:

<http://www.homelandsecurity.ohio.gov/dma/dma.asp>

- Be sure you have the correct DMA form. If you are applying for a state issued license, permit, certification or registration, the "State Issued License" DMA form must be completed (HLS 0036). If you are applying for employment with a government entity, the "Public Employment" DMA form must be completed (HLS 0037). If you are obtaining a contract to conduct business with or receive funding from a government entity, the "Government Business and Funding Contracts" DMA form must be completed (HLS 0038).
- Your DMA form is to be submitted to the issuing agency or entity. "Issuing agency or entity" means the government agency or office that has requested the form from you or the government agency or office to which you are applying for a license, employment or a business contract. For example, if you are seeking a business contract with the Ohio Department of Commerce's Division of Financial Institutions, then the form needs to be submitted to the Department of Commerce's Division of Financial Institutions. Do NOT send the form to the Ohio Department of Public Safety UNLESS you are seeking a license from or employment or business contract with one of its eight divisions listed below.
- Department of Public Safety Divisions:

Administration	Ohio Homeland Security*
Ohio Bureau of Motor Vehicles	Ohio Investigative Unit
Ohio Emergency Management Agency	Ohio Criminal Justice Services
Ohio Emergency Medical Services	Ohio State Highway Patrol
- * DO **NOT** SEND THE FORM TO OHIO HOMELAND SECURITY UNLESS OTHERWISE DIRECTED. FORMS SENT TO THE WRONG AGENCY OR ENTITY WILL NOT BE PROCESSED.

PUBLIC EMPLOYMENT
In accordance with section 2909.34 of the Ohio Revised Code

DECLARATION REGARDING MATERIAL ASSISTANCE/NONASSISTANCE TO A TERRORIST ORGANIZATION

This form serves as a declaration by an applicant for public employment of material assistance/nonassistance to an organization on the U.S. Department of State Terrorist Exclusion List ("TEL"). Please see the Ohio Homeland Security Division Web site for a copy of the TEL.

Any answer of "yes" to any question, or the failure to answer "no" to any question on this declaration shall serve as a disclosure that material assistance to an organization identified on the U.S. Department of State Terrorist Exclusion List has been provided. Failure to disclose the provision of material assistance to such an organization or knowingly making false statements regarding material assistance to such an organization is a felony of the fifth degree.

For the purposes of this declaration, "material support or resources" means currency, payment instruments, other financial securities, funds, transfer of funds, financial services, communications, lodging, training, safe houses, false documentation or identification, communications equipment, facilities, weapons, lethal substances, explosives, personnel, transportation, and other physical assets, except medicine or religious materials.

LAST NAME		FIRST NAME		MIDDLE INITIAL
HOME ADDRESS				
CITY		STATE	ZIP	COUNTY
HOME PHONE () -		WORK PHONE () -		

DECLARATION

In accordance with section 2909.32 (A)(2)(b) of the Ohio Revised Code

For each question, indicate either "yes," or "no" in the space provided. Responses must be truthful to the best of your knowledge.

- Are you a member of an organization on the U.S. Department of State Terrorist Exclusion List? Yes No
- Have you used any position of prominence you have with any country to persuade others to support an organization on the U.S. Department of State Terrorist Exclusion List? Yes No
- Have you knowingly solicited funds or other things of value for an organization on the U.S. Department of State Terrorist Exclusion List? Yes No
- Have you solicited any individual for membership in an organization on the U.S. Department of State Terrorist Exclusion List? Yes No
- Have you committed an act that you know, or reasonably should have known, affords "material support or resources" to an organization on the U.S. Department of State Terrorist Exclusion List? Yes No
- Have you hired or compensated a person you knew to be a member of an organization on the U.S. Department of State Terrorist Exclusion List, or a person you knew to be engaged in planning, assisting, or carrying out an act of terrorism? Yes No

If an applicant's employment is denied due to a positive indication on this form, the applicant may request the Ohio Department of Public Safety to review the denial. Please see the Ohio Homeland Security Web site for information on how to file a request for review.

CERTIFICATION

I hereby certify that the answers I have made to all of the questions on this declaration are true to the best of my knowledge. I understand that if this declaration is not completed in its entirety, it will not be processed and I will be automatically disqualified. I understand that I am responsible for the correctness of this declaration. I understand that failure to disclose the provision of material assistance to an organization identified on the U.S. Department of State Terrorist Exclusion List, or knowingly making false statements regarding material assistance to such an organization is a felony of the fifth degree. I understand that any answer of "yes" to any question, or the failure to answer "no" to any question on this declaration shall serve as a disclosure that material assistance to an organization identified on the U.S. Department of State Terrorist Exclusion List has been provided by myself or my organization. If I am signing this on behalf of a company, business or organization, I hereby acknowledge that I have the authority to make this certification on behalf of the company, business or organization referenced above.

APPLICANT SIGNATURE X	DATE
---------------------------------	------

STEP 3: Acknowledgment

The public employer identified in Step 2 has identified you as an independent contractor or another classification other than a public employee. Ohio law requires that you acknowledge in writing that you have been informed that the public employer identified in Step 2 has classified you as an independent contractor or another classification other than a public employee for the services described in Step 2 and that you have been advised that contributions to OPERS will not be made on your behalf for these services.

In accordance with Ohio Administrative Code section 145-1-42(A)(2), an independent contractor means an individual who:

- Is a party to a bilateral agreement which may be a written document, ordinance or resolution that defines the compensation, rights, obligations, benefits and responsibilities of both parties;
- Is paid a fee, retainer or other payment by contractual arrangement for particular services;
- Is not eligible for workers' compensation or unemployment compensation;
- May not be eligible for employee fringe benefits such as vacation or sick leave;
- Does not appear on a public employer's payroll;
- Is required to provide his own supplies and equipment, and provide and pay his assistants or replacements if necessary;
- Is not controlled or supervised by personnel of the public employer as to the manner of work; and
- Should receive an Internal Revenue Service form 1099 for income tax reporting purposes.

An independent contractor is not a public employee and shall not become a contributor to the retirement system. If you disagree with the public employer's classification, you may contact OPERS to request a determination as to whether you are a public employee eligible for OPERS contributions for these services. Ohio law provides that a request for a determination must be made within five years after you begin providing personal services to the public employer, unless you are able to demonstrate through medical records to the Board's satisfaction that at the time the five-year period ended, you were physically or mentally incapacitated and unable to request a determination. Under the OPERS Health Reimbursement Arrangement (HRA) and the OPERS Retiree Medical Account (RMA), re-employed retirees who are not independent contractors are not eligible for a monthly allowance or reimbursement of any medical expenses incurred during the re-employment period. If you are not an independent contractor and receive an allowance or reimbursements, you may be liable to OPERS and/or the applicable plan.

By signing this form, you are acknowledging that the public employer for whom you are providing personal services has informed you that you have been classified as an independent contractor or another classification other than a public employee and that no contributions will be remitted to OPERS for the personal services you provide to the public employer. If you entered into a contract to provide services as an independent contractor, you are acknowledging that you meet the requirements of an "independent contractor" as that term is defined in Ohio Administrative Code section 145-1-42(A)(2). If you begin to provide services as an independent contractor to the same employer from which you retired, or to any employer if less than two months after the retirement allowance commences, you are acknowledging the pension portion of your benefit will be forfeited during the period of the contract. You are acknowledging that the annuity portion of your benefit will be suspended and will be paid in a lump sum upon termination of the contract, and you may be liable to the retirement system for any amounts incorrectly paid from the plan(s). You are also acknowledging that you are not eligible for a monthly allowance or reimbursement of medical expenses incurred during the period you are providing services under the OPERS HRA or the OPERS RMA, and you may be liable to OPERS and/or the applicable plan for any allowance or reimbursements received. This acknowledgment will remain valid as long as you continue to provide the same services to the same employer with no break in service regardless of whether the initial contract period is extended by any additional agreement of the parties. You also acknowledge that you understand you have the right to request a determination of your eligibility for OPERS membership if you disagree with the public employer's classification. **This form must be retained by the public employer and a copy sent to OPERS. The public employer's failure to retain this acknowledgment may extend your right to request a determination beyond the five years referenced above.**

Signature _____ Today's Date ____/____/____
Do not print or type name



Sales and Use Tax Construction Contract Exemption Certificate

Identification of Contract:

Contractee's (owner's) name _____

Exact location of job/project _____

Name of job/project as it appears on contract documentation _____

The undersigned hereby certifies that the tangible personal property purchased under this exemption certificate is purchased exempt of the tax for incorporation into:

A building used exclusively for charitable purposes by a nonprofit organization operated exclusively for charitable purposes as defined in Ohio Revised Code (R.C.) section 5739.02(B)(12);	Real property that is owned, or will be accepted for ownership at the time of completion, by the United States government, its agencies, the state of Ohio or an Ohio political subdivision;
A horticulture structure or livestock structure for a person engaged in the business of horticulture or producing livestock;	Real property under a construction contract with the United States government, its agencies, the state of Ohio, or an Ohio political subdivision;
The original construction of a sports facility under R.C. section 307.696;	A building under a construction contract with an organization exempt from taxation under section 501(c)(3) of the Internal Revenue Code of 1986 when the building is to be used exclusively for the organization's exempt purposes;
A hospital facility entitled to exemption under R.C. section 140.08;	
A computer data center entitled to exemption under R.C. 122.175; ___% exempt per OH Dept. of Development	A house of public worship or religious education;
A megaproject entitled to exemption as described in R.C. 5739.02(B)(13).	Building and construction materials and services sold for incorporation into real property comprising a convention center that qualifies for property tax exemption under R.C. 5709.084 (until one calendar year after the construction is completed).
Real property outside this state if such materials and services, when sold to a construction contractor in the state in which the real property is located for incorporation into real property in that state, would be exempt from a tax on sales levied by that state;	

The original of this certificate must be signed by the owner/contractee and/or government official and must be retained by the prime contractor. Copies must be maintained by the owner/contractee and all subcontractors. When copies are issued to suppliers when purchasing materials, each copy must be signed by the contractor or subcontractor making the purchase.

Prime Contractor

Name _____
Signed by _____
Title _____
Street address _____
City, state, ZIP code _____
Date _____

Owner/Contractee

Name _____
Signed by _____
Title _____
Street address _____
City, state, ZIP code _____
Date _____

Subcontractor

Name _____
Signed by _____
Title _____
Street address _____
City, state, ZIP code _____
Date _____

Political Subdivision

Name _____
Signed by _____
Title _____
Street address _____
City, state, ZIP code _____
Date _____



Sales and Use Tax Contractor's Exemption Certificate

Identification of Contract:

Contractee's (owner's) name _____

Exact location of job/project _____

Name of job/project as it appears
on contract documentation _____

The undersigned hereby certifies that the tangible personal property purchased under this exemption from:

_____ Vendor's name

was purchased for incorporation into:

<input type="checkbox"/>	Real property under a construction contract with the United States government, its agencies, the state of Ohio, or an Ohio political subdivision;	<input type="checkbox"/>	Real property that is owned, or will be accepted for ownership at the time of completion, by the United States government, its agencies, the state of Ohio or an Ohio political subdivision;
<input type="checkbox"/>	A horticulture structure or livestock structure for a person engaged in the business of horticulture or producing livestock;	<input type="checkbox"/>	A house of public worship or religious education;
<input type="checkbox"/>	A building used exclusively for charitable purposes by a nonprofit organization operated exclusively for charitable purposes as defined in Ohio Revised Code (R.C.) section 5739.02(B)(12);	<input type="checkbox"/>	A building under a construction contract with an organization exempt from taxation under section 501(c)(3) of the Internal Revenue Code of 1986 when the building is to be used exclusively for the organization's exempt purposes;
<input type="checkbox"/>	The original construction of a sports facility under R.C. section 307.696;	<input type="checkbox"/>	A hospital facility entitled to exemption under R.C. section 140.08;
<input type="checkbox"/>	Real property outside this state if such materials and services, when sold to a construction contractor in the state in which the real property is located for incorporation into real property in that state, would be exempt from a tax on sales levied by that state;	<input type="checkbox"/>	Building and construction materials and services sold for incorporation into real property comprising a convention center that qualifies for property tax exemption under R.C. 5709.084 (until one calendar year after the construction is completed).

This certificate may be used by a contractee or subcontractor when buying materials for a construction contract where the owner/contractee has claimed one of the above exemptions. This certificate covers all sales of materials by the above-named vendor to the contractor or subcontractor for this particular construction contract only.

Contractor/subcontractor

Name

Signed by

Title

Street address

City, state, ZIP code

Date



Sales and Use Tax Blanket Exemption Certificate

The purchaser hereby claims exception or exemption on all purchases of tangible personal property and selected services made under this certificate from:

_____ (Vendor's name)

and certifies that the claim is based upon the purchaser's proposed use of the items or services, the activity of the purchase, or both, as shown hereon:

Purchaser must state a valid reason for claiming exception or exemption.

Purchaser's name

Purchaser's type of business

Street address

City, state, ZIP code

Signature

Title

Date signed

Vendor's license number, if any

Vendors of motor vehicles, titled watercraft and titled outboard motors may use this certificate to purchase these items under the "resale" exception. Otherwise, purchaser must comply with either rule 5703-9-10 or 5703-9-25 of the Administrative Code. This certificate cannot be used by construction contractors to purchase material for incorporation into real property under an exempt construction contract. Construction contractors must comply with rule 5703-9-14 of the Administrative Code.